



Place this chapter in the Shakes/Desserts section of the Equipment Manual.

Manufactured exclusively for McDonald's® by

Taylor Company  
750 N. Blackhawk Blvd.  
Rockton, IL 61072  
Phone: (815) 624-8333  
Toll Free Number  
Outside Illinois:  
1 (800) 228-8309  
Inside Illinois:  
1 (800) 851-5639  
Fax: (815) 624-8000



**Table of Contents**

|                                      |         |
|--------------------------------------|---------|
| Introduction .....                   | Page 1  |
| Safety .....                         | Page 1  |
| Parts Identification/Functions ..... | Page 5  |
| Important to the Operator .....      | Page 10 |
| Daily Opening Procedures .....       | Page 14 |
| 4 Hour Cleaning Procedures .....     | Page 15 |
| Product System .....                 | Page 16 |
| Daily Closing Procedures .....       | Page 19 |
| Weekly Cleaning Procedures .....     | Page 25 |
| Weekly Calibration Procedures .....  | Page 39 |
| LCD Screens .....                    | Page 46 |
| Main Menu .....                      | Page 46 |
| Manager Menu .....                   | Page 48 |
| Shaver Blade Replacement .....       | Page 52 |
| Troubleshooting Guide .....          | Page 56 |
| Parts Replacement Schedule .....     | Page 59 |
| Parts Warranty Explanation .....     | Page 60 |
| Ordering/Service Information .....   | Page 61 |
| Wiring Diagram .....                 | Page 62 |

**Warranty**

A warranty checkout card is shipped with all new equipment that leaves the factory. The warranty checkout card is packed in an envelope which also contains this operator's manual. Refer to the warranty checkout card and the warranty classifications listed in the Parts Identification/Function section when service is performed on your machine.

It is recommended that the operator take the necessary time to carefully read through the complete warranty information contained in the warranty checkout card. Any questions or unclear statements found within the card should be made clear to you upon delivery of the machine. Thoroughly understand your warranty protection before you begin operation.

For any questions pertaining to the Taylor warranty, please contact your authorized Taylor Distributor or Taylor Company, Rockton, Illinois 61072.

This manual is for the exclusive use of licensees and employees of McDonald's Corporation.



## INTRODUCTION

The Model C029 Blended Ice Machine is a combination ice shaver/blender that can dispense up to seven flavors, with the additional option of being blended with yogurt.

The product flavors and yogurt are stored in a refrigerated cabinet.

When your machine is delivered, or if it has been in the OFF position for more than 24 hours, disassemble the machine following the “**Weekly Cleaning Procedures**” on page 25. Follow the Equipment Set-Up procedures to re-assemble your machine.

The machine must be disassembled, cleaned, and sanitized at least once a day. Product lines must be cleaned and sanitized weekly.

It is recommended that these operating procedures be followed closely to insure correct assembly and disassembly of the machine.

## SAFETY

Always follow these safety precautions when operating the machine:



**DO NOT** operate the machine without reading this Operator's Manual. Failure to follow this instruction may result in equipment damage, poor equipment performance, health hazards, or personal injury.



This appliance is to be used only by trained personnel. It is not intended for use by children or people with reduced physical, sensory, or mental capabilities, or lack of experience and knowledge, unless given supervision or instruction concerning the use of the appliance by a person responsible for their safety. Children should be supervised to ensure that they do not play with the appliance.



Access to the service area of the unit is restricted to persons having knowledge and practical experience with the appliance, in particular as far as safety and hygiene are concerned.



- **DO NOT** operate the machine unless it is properly grounded.
- **DO NOT** operate the machine with larger fuses than specified on the data label.
- All repairs must be performed by an authorized Taylor service technician.
- The main power supplies to the machine must be disconnected prior to performing any repairs.
- Cord Connected Units: Only Taylor authorized service technicians may install a plug on this machine.
- Stationary appliances which are not equipped with a power cord and a plug or other device to disconnect the appliance from the power source must have an all-pole disconnecting device with a contact gap of at least 3 mm installed in the external installation.
- Each machine requires one dedicated power supply.
- Appliances that are permanently connected to fixed wiring and for which leakage currents may exceed 10 mA, particularly when disconnected or not used for long periods, or during initial installation, shall have protective devices such as a GFI, to protect against the leakage of current, installed by the authorized personnel to the local codes.

- Supply cords used with this machine shall be oil-resistant, sheathed flexible cable not lighter than ordinary polychloroprene or other equivalent synthetic elastomer-sheathed cord (Code designation 60245 IEC 57) installed with the proper cord anchorage to relieve conductors from strain, including twisting, at the terminals and protect the insulation of the conductors from abrasion.

If the supply cord is damaged, it must be replaced by the manufacturer, its service agent, or similarly qualified person, in order to avoid a hazard.

Failure to follow these instructions may result in personal injury, equipment damage, or poor freezer performance.



This equipment is provided with a grounding lug that is to be properly attached to the rear of the frame by the authorized installer. The installation location is marked by the equipotential bonding symbol (5021 of IEC 60417-1) on the removable panel and the frame.



This appliance is only intended to be installed in a location where its use and maintenance is restricted to trained personnel.



**DO NOT** install the machine in an area where a water jet could be used and do not use a water jet to clean or rinse the unit. Failure to follow these instructions may result in serious electrical shock.



This equipment uses CO<sub>2</sub> and must be installed in an area with adequate ventilation. CO<sub>2</sub> in high concentrations is toxic to humans and may cause asphyxiation in confined areas.



**DO NOT** operate the machine unless all service panels and access doors are restrained with screws. Failure to follow this

instruction may result in severe personal injury from hazardous moving parts.



**DO NOT** remove any parts unless all control switches are in the OFF position. Failure to follow this instruction may result in severe personal injury from hazardous moving parts.



**DO NOT** put objects or fingers near the shaver or pitcher blades. Failure to follow this instruction may result in contaminated product or personal injury from blade contact.



**CAUTION-SHARP EDGES:** Two people are required to handle the cup dispenser. Protective gloves must be worn and the mounting holes must NOT be used to lift or hold the dispenser. Failure to follow this instruction can result in personal injury to fingers or equipment damage.



This unit must be placed on a level surface to avoid the hazard of tipping. Extreme care should be taken in moving this equipment for any reason. Two or more persons are required to safely move this unit. Failure to comply may result in personal injury or equipment damage.



An approved cleaning/sanitizing solution containing an active chlorine concentrate of 100 - 200 PPM must be used when cleaning and sanitizing this machine.



Install potable water connection with adequate back-flow protection to comply with applicable National, State and local codes.

This machine is designed to operate indoors, under normal ambient temperatures of 70° - 75°F (21° - 24°C). The machine has successfully performed in high ambient temperatures of 104°F (40°C) at reduced capacities.

**DO NOT** obstruct air intake and discharge openings. A minimum air space is required for adequate air flow. Failure to follow this instruction may cause poor equipment performance and damage to the machine.

**NOTICE** all warning labels that have been attached to the machine to further point out safety precautions to the operator.

|   |  |
|---|--|
|  | <p><b>WARNING!</b></p> <p>Some consumers are highly allergic to strawberries. In some severe cases, allergic reactions to strawberries can cause death. When blending strawberry product, make sure excess product is removed from the pitcher to eliminate the fear of product carryover.</p> |
|---|--|

**HAZARD COMMUNICATION STANDARD (HCS) - The procedure(s) in this manual include the use of chemical products. See the Hazard Communication Standard (HCS) manual for the appropriate Material Safety Data Sheet(s) (MSDS). When sanitizer is used, it must always have a contact time of 5 minutes. Afterward, if required by your Local code, rinse with clean water.**

This piece of equipment is made in America and has American sizes of hardware. All metric conversions are approximate and vary in size.

**NOISE LEVEL:** This unit meets the airborne noise emission standard according to the applicable European Directive.



If the crossed out wheeled bin symbol is affixed to this product, it signifies that this product is compliant with the EU Directive as well as other similar legislation in effect after August 13, 2005. Therefore, it must be collected separately after its use is completed, and cannot be disposed as unsorted municipal waste.

The user is responsible for returning the product to the appropriate collection facility, as specified by the local code.

For additional information regarding applicable local laws, please contact the municipal facility and/or local distributor.



## PARTS IDENTIFICATION/FUNCTIONS

### Exploded View (See Figure 1 )

| ITEM | PART NO.   | DESCRIPTION                       | QTY. | FUNCTION  | WARR. CLASS |
|------|------------|-----------------------------------|------|---|-------------|
| 1    | 065194-2B  | Cover-Ice Hopper                  | 1    | Covers the top of the ice hopper.   | 000         |
| 2    | 065194-2A  | Hopper-Ice Bin Only               | 1    | Ice container.  | 103         |
| 3    | X66687     | Dispenser A.-Cup                  | 1    | Dispenses drink cups.   | 103         |
| 4    | 065194-35  | Pitcher-Blender                   | 2    | Ice and product blending container.   | 103         |
| ☆4a  | 065194-35G | Pitcher A.-Guard                  | 2    | Ice and product blending container equipped with a guard, used in International markets, only. ( <b>Note:</b> Some markets receive 3 pitchers.) |             |
| 5    | X68329     | Panel A.-Cart- Rear               | 1    | Panel providing access to internal components. It also directs air up and out of the machine.   | 103         |
| 6    | 037734     | Screw-10-32X1/2 Slotted Truss     | *63  | Attaches access panel in place.   | 000         |
| 7    | 064995     | Grate-Stand-Pitcher               | 1    | Splash shield.  | 103         |
| 8    | 066511     | Pan-Drip-Rack Rinser              | 1    | Used to catch product and water draining from the pitchers.   | 103         |
| 9    | X66755     | Actuator A.-Rinser                | 1    | Used to activate the water rinser.  | 103         |
| 10   | 064997     | Grate-Bowl Rinse                  | 1    | Holds the rinser actuator and the strainer.   | 103         |
| 11   | X66311     | Strainer A.-Sink                  | 1    | A strainer which keeps particles from plugging up the rinser drain.   | 000         |
| 12   | 058501     | Caster-3" Rigid - 4 Hole Plate    | 2    | Wheels which support the unit and allow easier movement.  | 103         |
| 13   | 058500     | Caster-3" Swivel                  | 2    | Wheels which support the unit and allow easier movement.  | 103         |
| 14   | 067488     | Pan-Cart*Bottom                   | 1    | Drip pan which is installed in the bottom of the refrigerated cabinet.  | 103         |
| 15   | X67076     | Shelf A.-Support-Bin              | 8    | Shelves that support the product bins in the refrigerated cabinet.  | 103         |
| 16   | X67726     | Bin A.-Mix                        | 8    | Container that holds the product bag in place.  | 103         |
| 17   | 064950-2   | Gasket-Door-Cart                  | 1    | Gasket that seals the refrigerated cabinet door.  | 000         |
| 18   | 067813     | Holder-Bottle                     | 1    | Holder for the drizzle bottles and whip cream holder cover. ( <b>Note:</b> Requires 053053 holding collar.)                                     | 103         |
| 19   | 046551     | Collar-Holding .730 D X .072 Slot | 8    | Holds the whipped cream holder and the cup lid holder.  | 103         |
| 20   | 001086     | Screw-#10-32X3/4 Slotted Oval     | *8   | Used to attach holding collar to inside door panel, lid holders to outside door panel, and lid holder collars to the left side step panel.      | 000         |

\* Total number used in assembly of the machine, not just those shown in illustration.

☆ Used in International Markets, only.

**Exploded View (See Figure 1)**

| <b>ITEM</b> | <b>PART NO.</b> | <b>DESCRIPTION</b>          | <b>QTY.</b> | <b>FUNCTION</b>  | <b>WARR. CLASS</b> |
|-------------|-----------------|-----------------------------|-------------|--|--------------------|
| 21          | 065194-10       | Skirt-Unit                  | 1           | Panel which covers the empty space between the ice shaver and the cabinet top. | 103                |
| 22          | 067691          | Holder-Can Whip Cream       | 1           | Holder for the whipped cream can.  | 103                |
| 23          | 067744          | Cover-Holder-Can Whip Cream | 1           | Covers whipped cream can holder when whipped cream can is removed.             | 103                |
| 24          | 065194-8        | Guard-Splash                | 2           | Helps prevent ice and product from splashing.                                  | 000                |
| 25          | 065194-7        | Chute-Shaver Ice            | 1           | Directs ice into the pitcher.  | 000                |
| 26          | 053053          | Collar-Holding              | 4           | Secures the lid holder to the machine.   | 103                |
| 27          | 067947          | Holder-Lid                  | 2           | Cup lid holder.  | 103                |
| **          | 065194-6B       | Blade-Shaver-Ice            | 1           | Shaves ice in the ice shaver.  | 000                |

\*Total number used in assembly of the machine, not just those shown in illustration.

\*\*Not Shown



# Exploded View

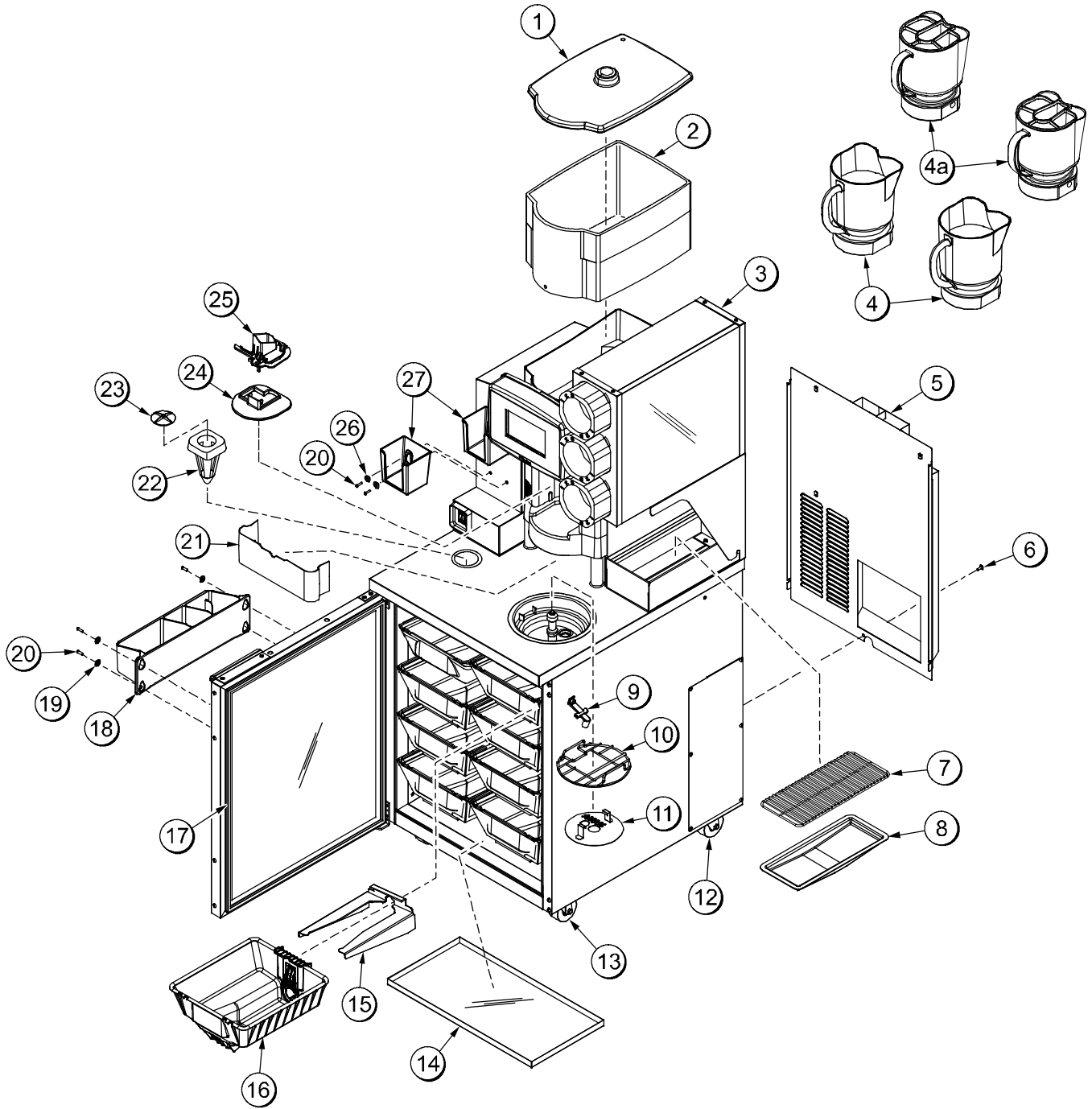

Figure 1

**Accessories (See Figure 2)**

| <b>ITEM</b> | <b>PART NO.</b> | <b>DESCRIPTION</b>                                      | <b>QTY.</b> | <b>FUNCTION</b>  | <b>WARR. CLASS</b> |
|-------------|-----------------|---|-------------|--|--------------------|
| 1           | 068460          | Brush-Tube-Mix  | 1           | Used to clean the dispenser head manifold.   | 000                |
| 2           | 039719          | Brush-End-Door-Spout                                    | 1           | Used to clean the dispenser head manifold.   | 000                |
| 3           | 023316          | Brush-Mix Pump Body                                     | 1           | Used to clean the pitchers and the ice hopper.   | 000                |
| 4           | X66468          | Tube A.-Cleaning  | 1           | Used when cleaning and sanitizing the product lines.   | 000                |
| 5           | 067970-W        | Pail-Wash   | 1           | Holds solution for cleaning.   | 000                |
| 6           | 067970-S        | Pail-Sanitize   | 1           | Holds solution for sanitizing.   | 000                |
| 7           | 067970-R        | Pail-Rinse  | 1           | Holds solution for rinsing.  | 000                |
| 8           | 066273-UV       | Cup-Calibration   | 1           | Calibration cylinder used to calibrate the ice and the product.                                    | 000                |
| 9           | X66750          | Line A.- Attachment-Cleaning<br>(Cleaning Hose Adaptor) | 1           | Used when cleaning and sanitizing the product lines.   | 103                |
| 10          | 067943          | Holder-Cord*Power                                       | 1           | The power cord is hung over this holder.   | 103                |
| 11          | X45080          | Bottle A.-Squeeze                                       | 1           | Plastic squirt bottle that is filled with sanitizing solution and used to clean the product lines. | 000                |
| ☆12         | 014753          | Brush-Draw Valve  | 1           | Brush used to clean the guarded pitcher used in International markets.                             | 000                |
| *           | 066756-96       | Hose-Corrugated-1 ID x 96                               | 1           | This is the drain line.  | 000                |

\* Not Shown.

☆ Used in International Markets, only.

Accessories

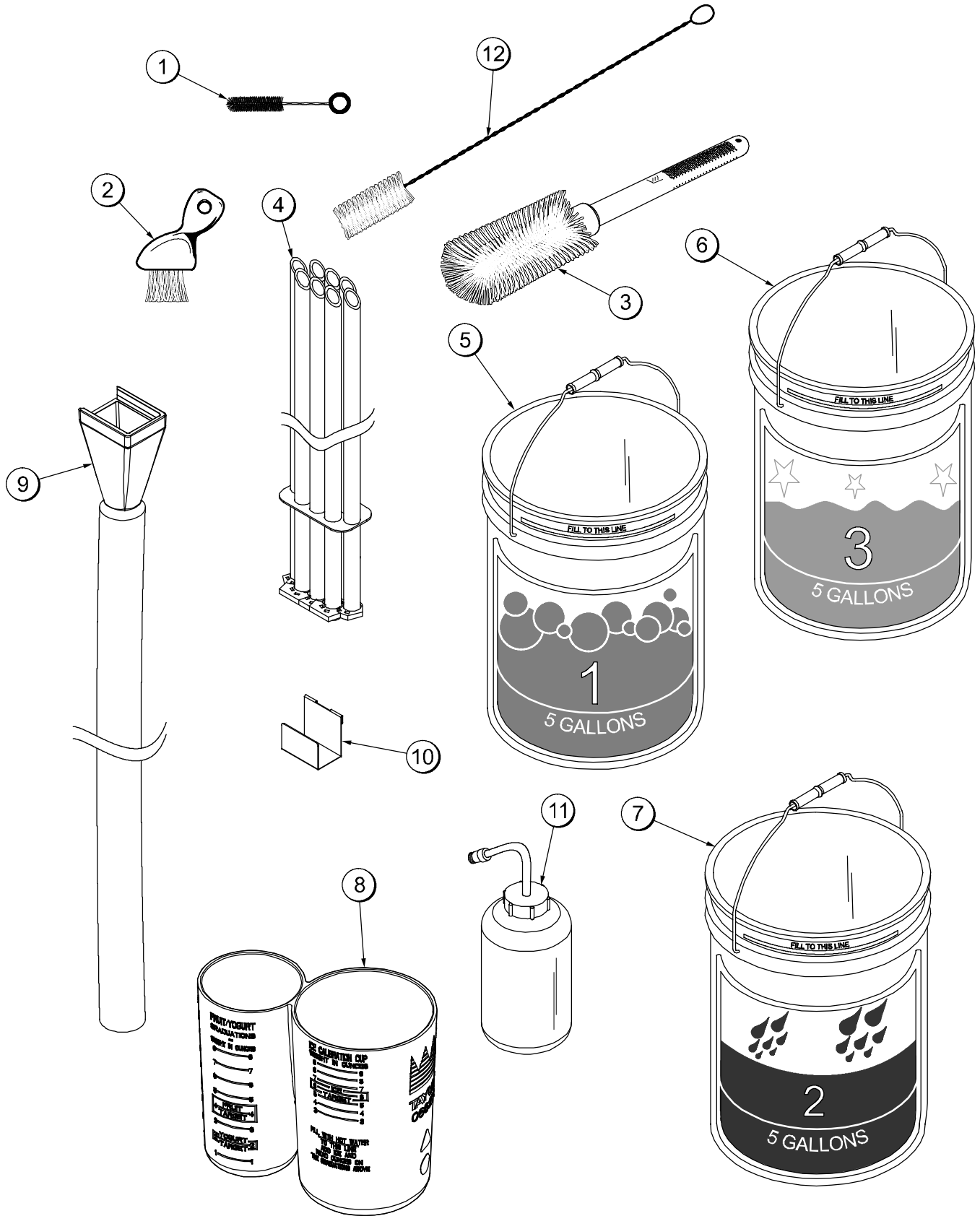

Figure 2

**IMPORTANT TO THE OPERATOR**

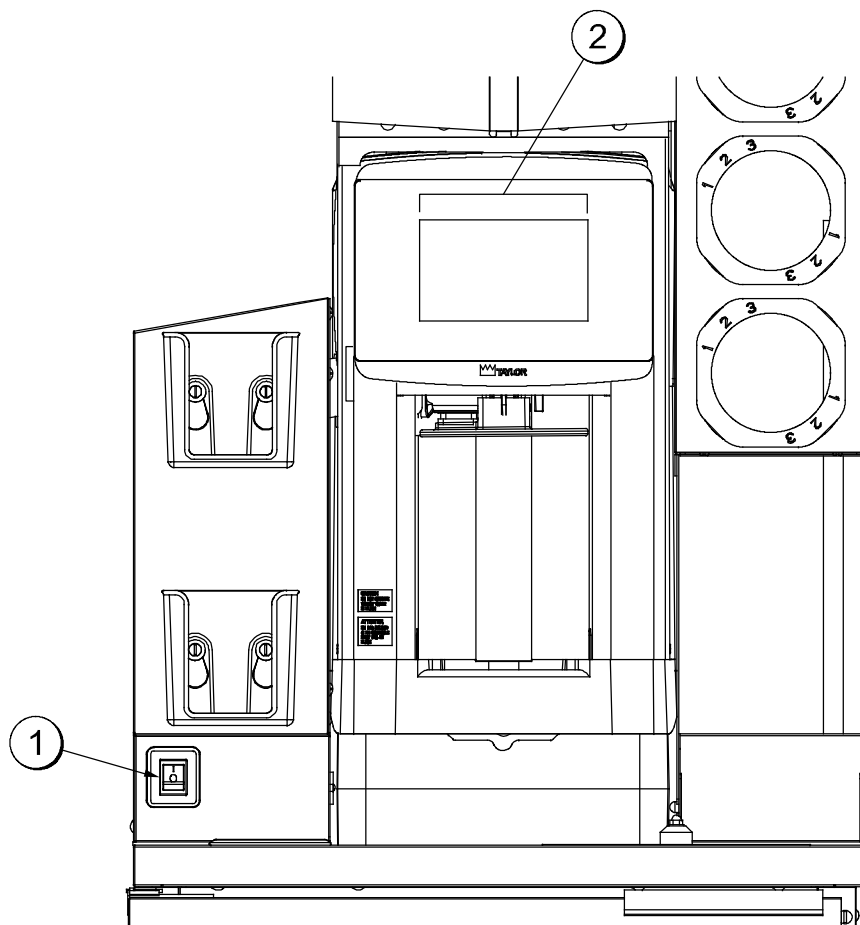

Figure 3

| ITEM | DESCRIPTION                  | FUNCTION  |
|------|------------------------------|---|
| 1    | Rocker Switch (Power Switch) | On/Off switch which powers the machine on or off.                                   |
| 2    | Touch Screen Control         | Interface screen which allows the operator to control the operation of the machine. |

## Touch Screen Control

The touch screen control allows the operator to control the functions of the machine. It is located in the front face of the blender.

## Blender Pitcher Rinse Station

The blender pitcher rinse station is timer controlled. Position the blender pitcher upside down, with the handle out, on the rinse station grate. (See Figure 4.)

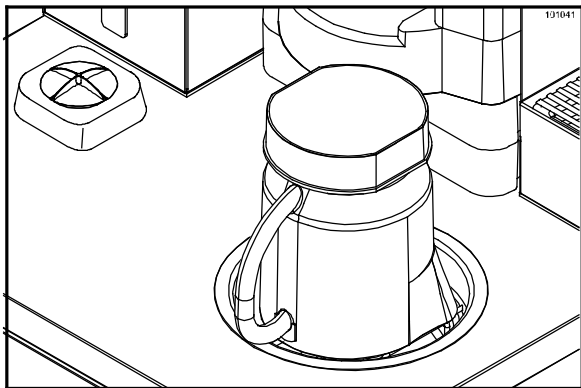

Figure 4

When the blender pitcher is placed on the rinse station grate, the spray nozzle is automatically activated. Water will spray the interior of the pitcher for approximately seven seconds and shut off automatically.

**Note:** The water shuts off immediately if the pitcher is removed before the seven seconds elapses.

After rinsing, the pitcher may be left on the rinse station or placed upside down on the pitcher stand grate.

**Note: Blender pitchers must be washed, rinsed, and sanitized every four hours to prevent a build-up of film on the pitchers.**



**DO NOT** put objects or fingers near the pitcher blade. Failure to follow this instruction may result in contaminated product or personal injury from blade contact.

## Ice Hopper

The ice hopper is located at the top of the blender. The ice hopper holds the ice until it is needed. When a drink is selected, the proper amount of ice is shaved and blended with the selected product in the blender pitcher. (See Figure 5.)

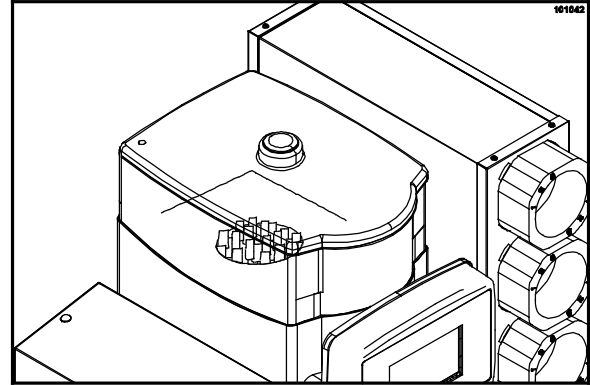

Figure 5

**Important:** The cover for the ice hopper must be in place for the machine to blend.

The cover must be washed, rinsed, and sanitized during the Daily Closing procedure.

The ice hopper must be emptied every day. It must be washed, rinsed, and sanitized during the Weekly Cleaning procedure.

### To remove ice from inside the ice hopper:

- Use a clean, sanitized ice scoop to remove as much ice as possible.
- Install a blender pitcher in the dispensing area and place the cover on the ice hopper. Press the ICE key until all remaining ice has dispensed into the blender pitcher. (See Figure 6.)
- Discard all ice that was removed from the ice hopper.

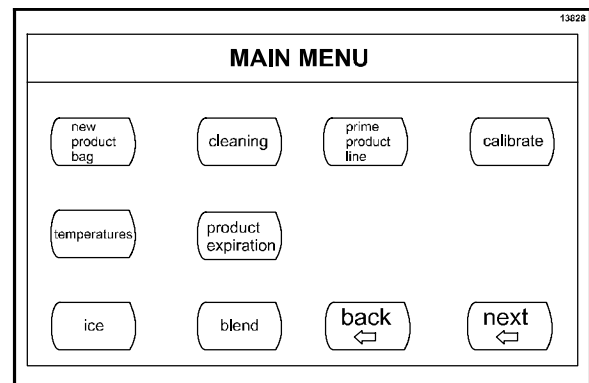

Figure 6

## Refilling the Ice Hopper

1. Add ice when the ice level drops to the "ADD ICE" line. (See Figure 7.)

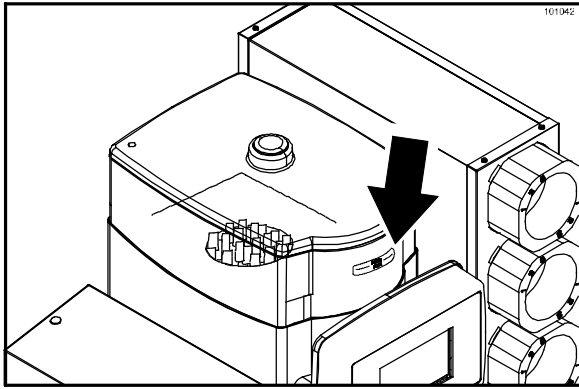

Figure 7

**Note:** Make sure the ice is not bridging (melted together) on the side of the ice hopper, which makes it appear full. If the ice is bridging, use a sanitized cup to push the ice down into the middle of the ice hopper.

2. Gather ice in a sanitized container.
3. Remove the ice hopper cover. (See Figure 8.)

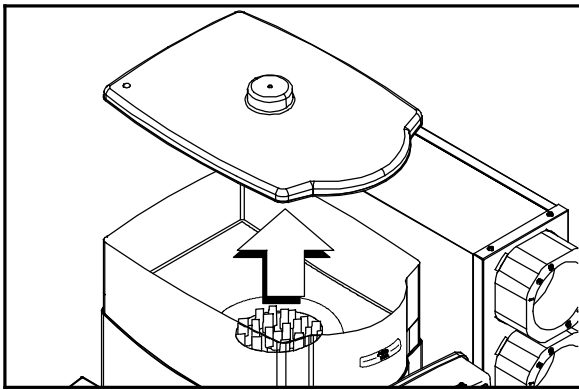

Figure 8

4. Pour the ice into the ice hopper. (See Figure 9.)

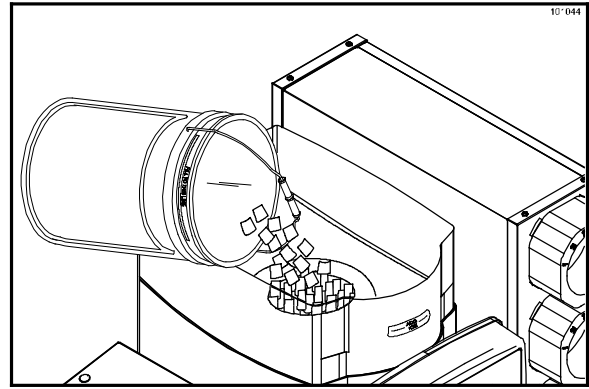

Figure 9

5. Reinstall the ice hopper cover. (See Figure 10.)

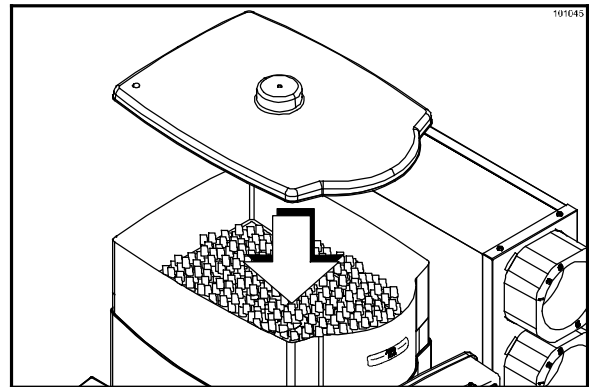

Figure 10

**Note:** The unit will not function without the ice hopper cover in place.

## Dispensing a Drink

1. Place a blender pitcher into the dispensing area. A pitcher can be removed from the rinse station grate or the pitcher stand grate. (See Figure 11.)

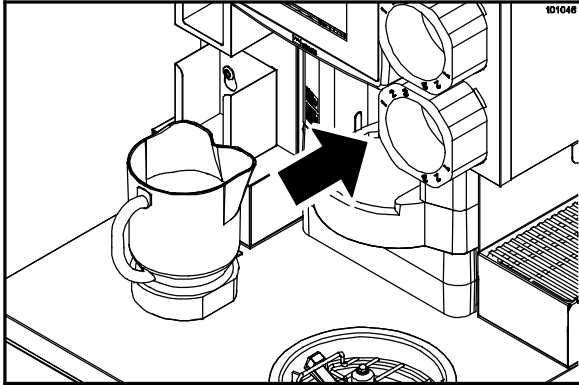

Figure 11

2. From the Beverage Selection Screen, press the appropriate product key. (See Figure 12.)

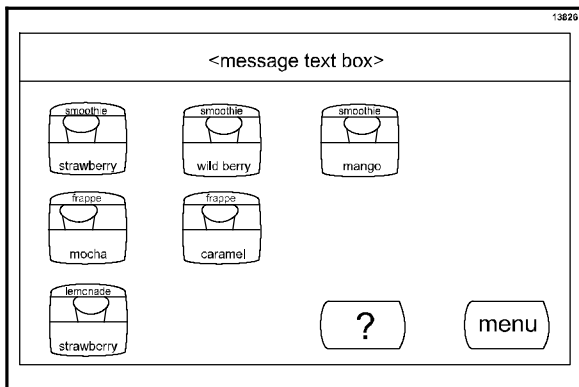

Figure 12

**Note:** The product keys have color-coded borders to indicate the product condition.

Green = Selected Product  
 Yellow = Product Low  
 Red = Product Out

3. The next screen to display will indicate the name of the selected product on the right side of the screen. (See Smoothie screen example in Figure 13.)

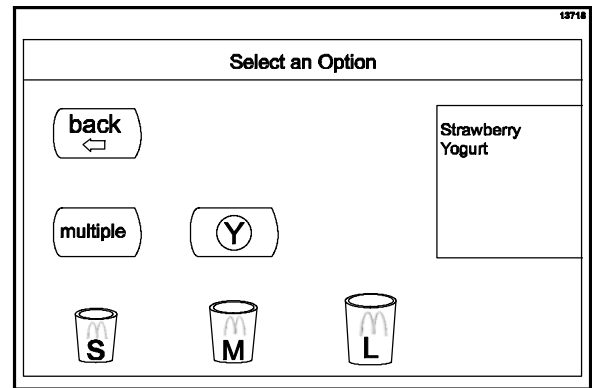





Figure 13

4. Select the desired options by pressing the appropriate keys on the screen. As each option is selected, it is listed on the right side of the screen. If an option is de-selected, that option is removed from the screen.

### Examples:

To remove yogurt from a drink, press the  key, which changes the graphic to . To add yogurt to a drink, press the  key, which changes the graphic to .

**Note:** To dispense multiples of the same drink, proceed to step 6.

5. Select the desired drink size: Small, Medium, or Large. The drink will dispense into the blender pitcher.

When a drink dispenses, the following sequence of events occurs:

- a. The product starts to dispense.
- b. The ice shaver and the blender are activated until the programmed amount of ice is delivered.
- c. After blending is complete, the screen will return to the Beverage Selection Screen.

**Note:** In order for a drink to dispense, the blender pitcher and the ice hopper cover must be in place.

- To dispense multiples of the same drink, press the “multiple” key. (See Figure 14.)

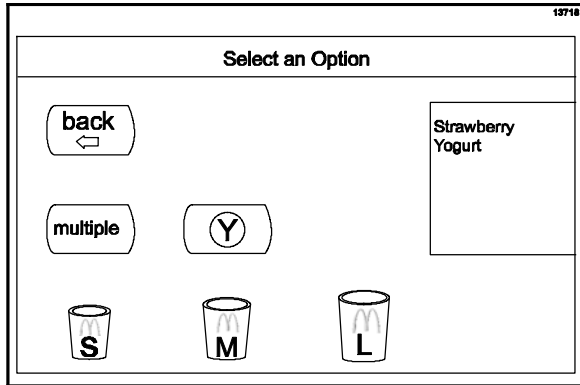

Figure 14

- “Multiple Size” is added to the options list. The “multiple” key changes into a “make drinks” key.
- Press the size key of the first drink size selection. The selected size will be added to the options list. Continue making size selections by pressing the appropriate size keys. (See Figure 15.)

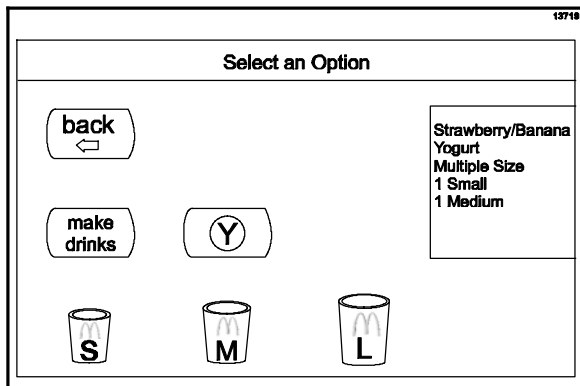

Figure 15

**Note:** To remove a drink size from the options list, press the corresponding size key repeatedly until that size is removed from the options list.

- When all size selections have been made, press the “make drinks” key. The unit will dispense the drinks.

**Note:** To remove the multiple drinks option from the options list, verify that no size selections are listed in the options list. Press the “make drinks” key. The screen will return to the Beverage Option Screen for dispensing a single drink.

## DAILY OPENING PROCEDURES

### Set Up - Complete the Following

**Make sure your hands are clean and sanitized before performing these next steps.**

**Note:** An approved cleaning/sanitizing solution containing an active chlorine concentrate of 100 - 200 PPM must be used when cleaning and sanitizing this machine. Use warm water and follow the manufacturer's specifications.

- Prepare a small amount of an approved sanitizing solution containing an active chlorine concentrate of 100 - 200 PPM.
- Return to the machine with a small amount of the sanitizing solution and a clean, sanitized towel. Wipe down the outside surfaces of the unit with the solution. Discard the used towel.
- Reinstall the ice hopper, ice hopper cover, blender pitchers, ice chute, splash guard, rinse station assembly (grate, actuator, and strainer), pitcher drying station (pitcher stand grate and drip pan), lid holders, syrup rail, skirt, and mix cabinet drip pan. Remove the whipped cream holder cover and install the whipped cream holder. (See Figure 16.)

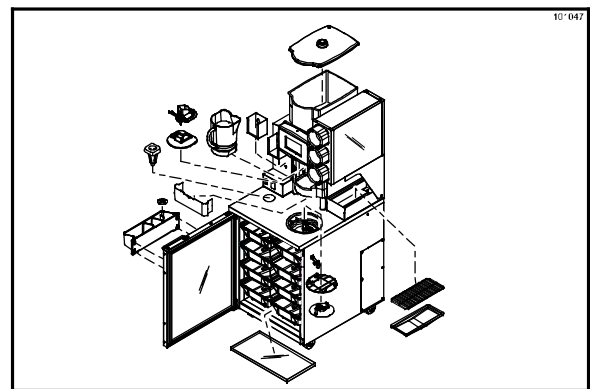

Figure 16

**Note:** The bottom product bins and shelves must be removed in order to install the mix cabinet drip pan.

- Place the whipped cream holder cover in the syrup rail for storage. Place a can of whipped cream in the whipped cream holder. Fill the cup dispensers and the cup lid holders.



## 4 HOUR CLEANING PROCEDURES

**Note:** When sanitizer is used, it must always have a contact time of 5 minutes. Afterward, if required by your Local code, rinse with clean water.

### Blender Pitcher and Splash Guard Cleaning

1. Remove the blender pitcher. Discard any remaining product into the back sink. Take the pitcher to the 3-compartment sink for cleaning. (See Figure 17.)

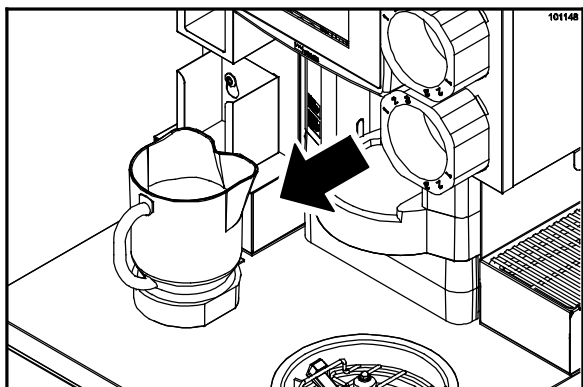

Figure 17

2. Remove the splash guard and take it to the 3-compartment sink for cleaning. (See Figure 18.)

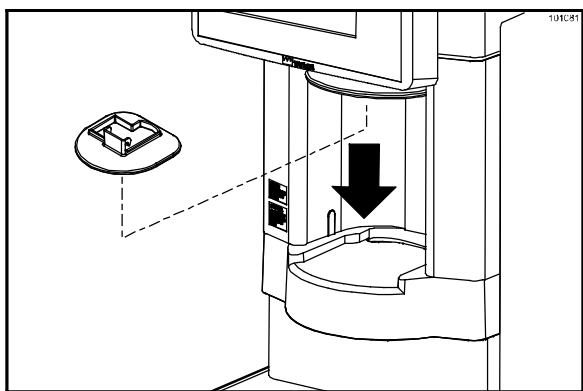

Figure 18

3. Wash the parts in a hot, approved cleaning solution. (See Figure 19.)



**CAUTION:** Use care when washing the blender pitcher. **DO NOT touch the pitcher blades with your hands.** Failure to follow this instruction may result in personal injury from blade contact.

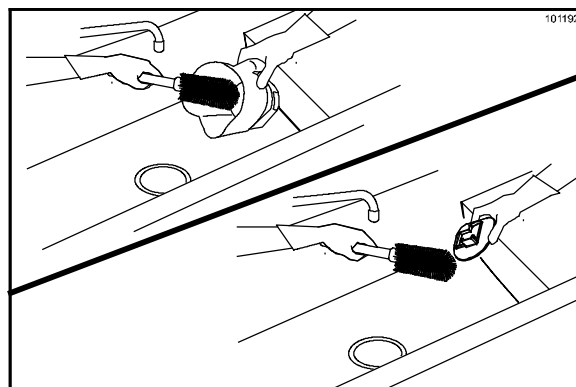

Figure 19

**International Units Only:** Use supplied brush to clean the guarded pitcher. Make sure to thoroughly clean the top, bottom, and all points where the guard contacts the pitcher cup.

4. Rinse the parts in cool, clean water.
5. Sanitize the parts in an approved sanitizing solution containing an active chlorine concentrate of 100 - 200 PPM. If required by your Local code, rinse with clean water.
6. Reinstall the splash guard. (See Figure 20.)

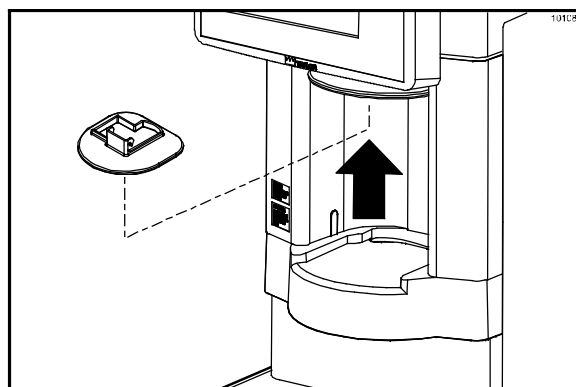

Figure 20

- Place the blender pitcher in the dispensing area. (See Figure 21.)

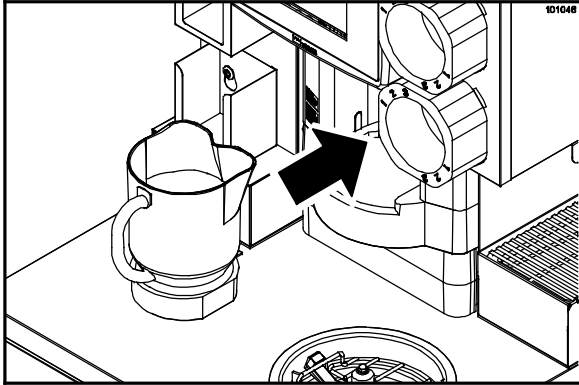

Figure 21

- Remove the product bin from the machine and place it on a stable, flat surface such as a counter top. (See Figure 24.)

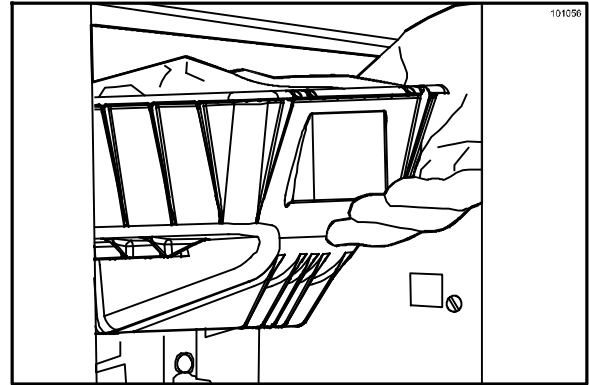

Figure 24

## PRODUCT SYSTEM

### Product Bag Replacement Procedure

- Press the Menu key to display the Main Menu screen. (See Figure 22.)

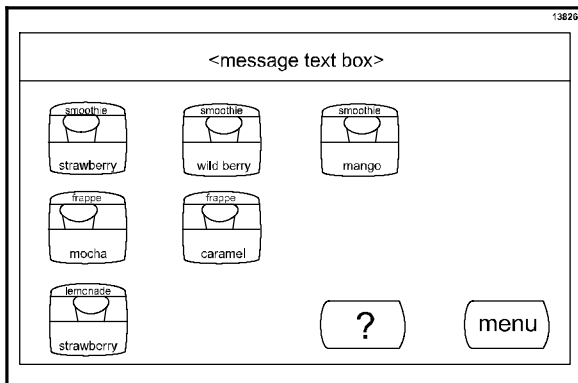

Figure 22

- Press the New Product Bag key. (See Figure 23.)

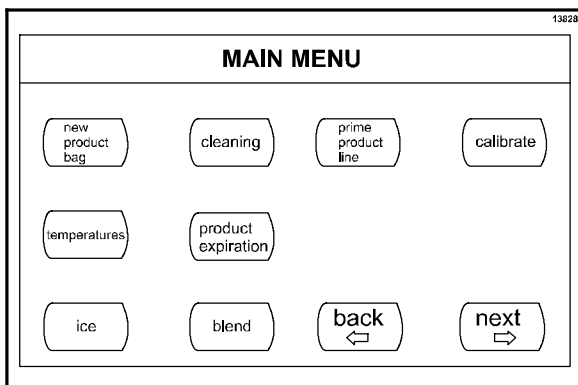

Figure 23

- Move the bin slide to the "open" position by (1) pulling the slide slightly away from the bin and (2) up, until it stops. Remove and discard the empty product bag. (See Figure 25.)

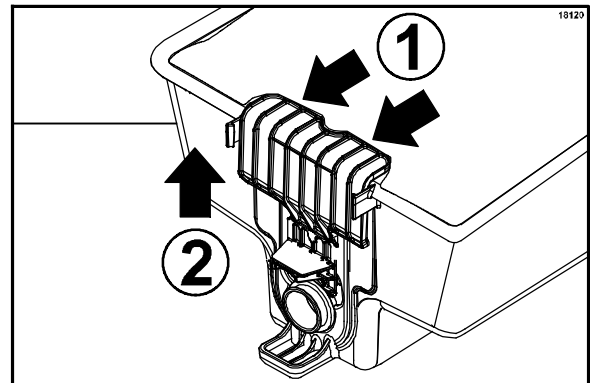

Figure 25

- Using a clean, sanitized cloth, wipe the inside of the bin before installing a new product bag. (See Figure 26.)

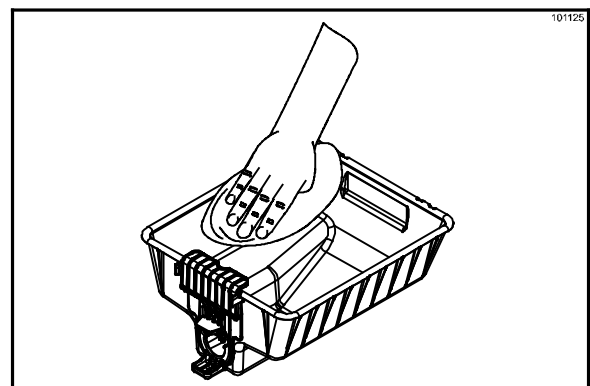

Figure 26

- Remove the bag of product from the box. (See Figure 27.)

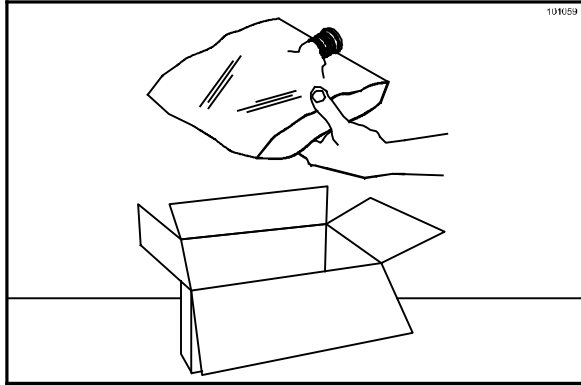

Figure 27

**Note:** See the quick guide label inside the bin for product bag installation procedures.

- Place the bag of product into the base of the product bin with the **spout facing down**. (See Figure 28.)

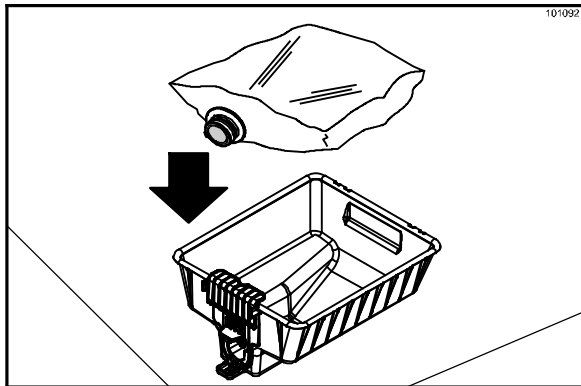

Figure 28

- Slide the product bag spout into the slot of the product bin. **IMPORTANT! Position the rear groove of the product bag spout into the slot of the product bin. Lock the spout into position by pushing down on the product bin slide until it snaps in place.** (See Figure 29.)

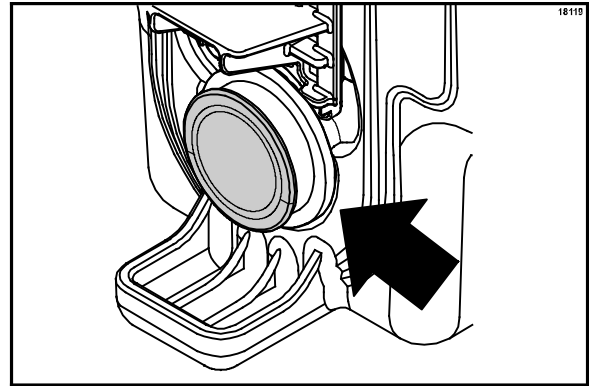

Figure 29

**IMPORTANT! Make sure the product bag is not pinched in the bin slot.**

- Arrange the product bag so it is flat and spread out in the bin. Attach the rear of the bag over the two bin hooks. (See Figure 30.)

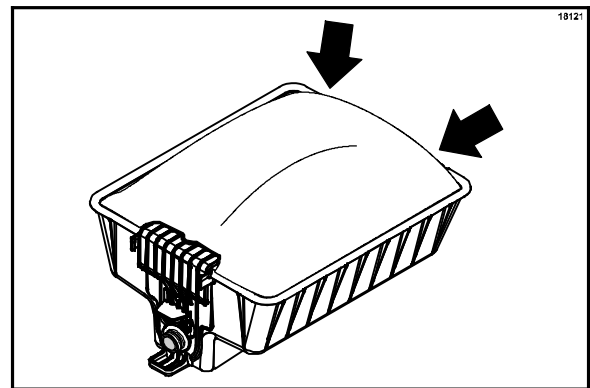

Figure 30

- Open the cap on the product bag and tear it off. (See Figure 31.)

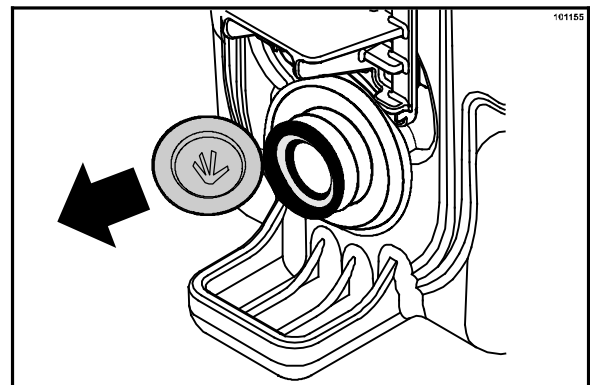

Figure 31

- Clean the syrup fitting in the cabinet, using an approved sanitizing solution

containing an active chlorine concentrate of 100 - 200 PPM and a clean, sanitized towel. (See Figure 32.)

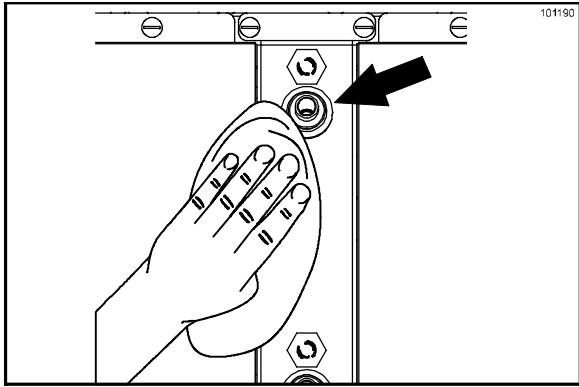

Figure 32

- If the product bin shelf is not installed, install the shelf over the collar and pin on the back wall of the product cabinet. (See Figure 33.)

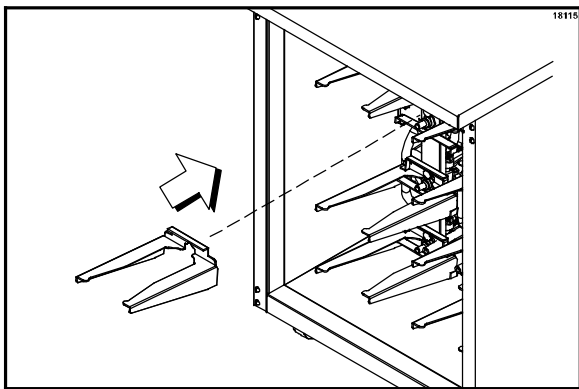

Figure 33

- Carefully place the product bin with the new product bag on the designated shelf in the refrigerated cabinet. Make sure the bag spout slides over the product tube. (See Figure 34.)

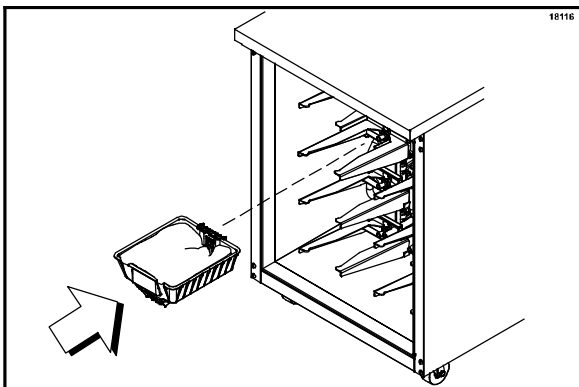

Figure 34

**Note:** There are eight product locations labeled in the refrigerated cabinet. Be sure to place the product bin with the new product bag into the appropriate location in the cabinet.

- Place a blender pitcher in the dispensing area. (See Figure 35.)

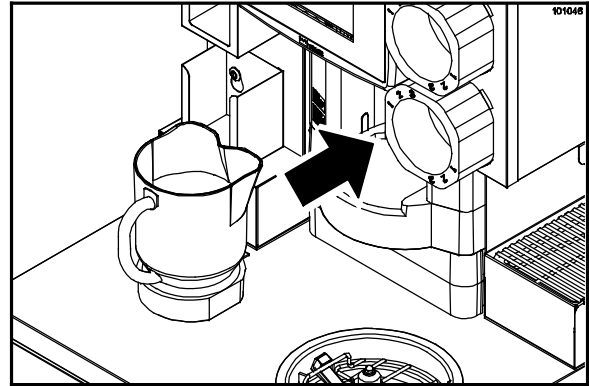

Figure 35

- Press the appropriate product key. (See Figure 36.)

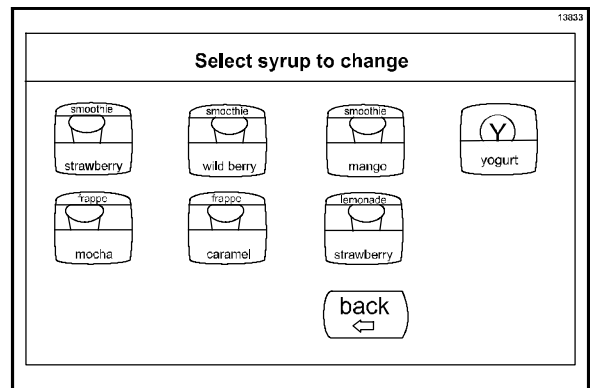

Figure 36

- The new product bag will begin priming. A bar graph screen will show the progress of the priming. The PAUSE key can be used to stop and restart the process. (See Figure 37.)

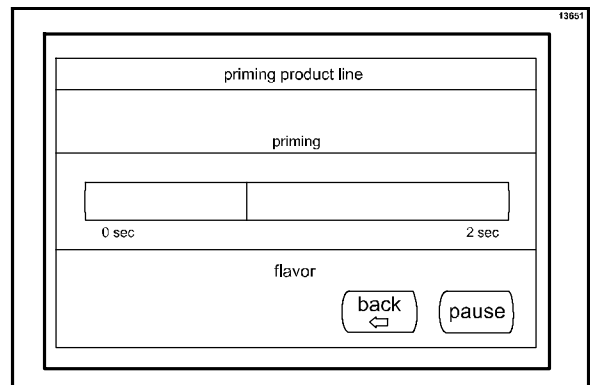

Figure 37

When the bag has finished priming, the screen will return to the Beverage Selection Screen. (See Figure 38.)

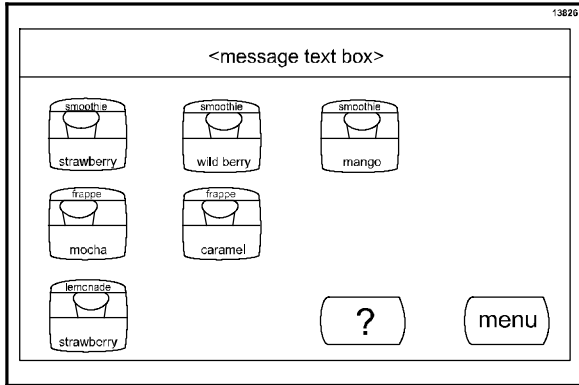

Figure 38

17. Remove the blender pitcher and discard the product into the back sink. (See Figure 39.)

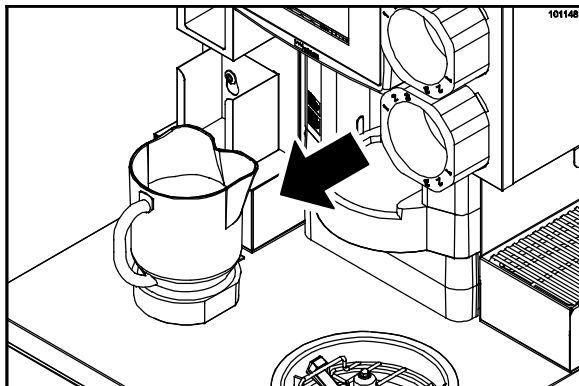

Figure 39

## DAILY CLOSING PROCEDURES

**This procedure must be done at the close of business.**

**Note:** When sanitizer is used, it must always have a contact time of 5 minutes. Afterward, if required by your Local code, rinse with clean water.

1. Press the MENU key to display the Main Menu screen. (See Figure 40.)

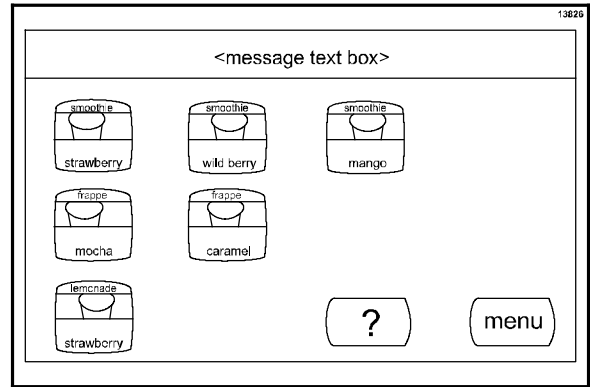

Figure 40

2. Press the CLEANING key. (See Figure 41.)

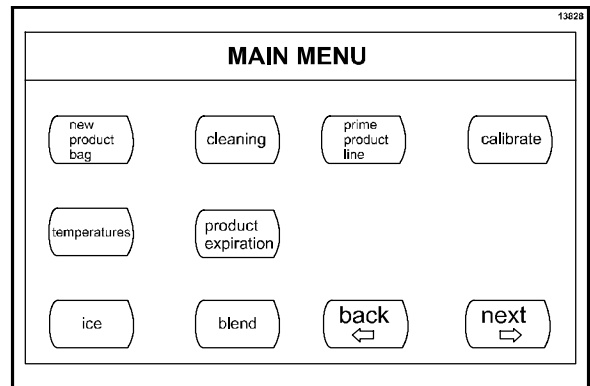

Figure 41

3. Press the DAILY key. (See Figure 42.)

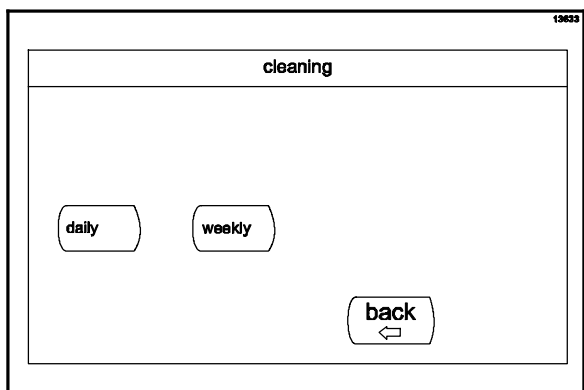

Figure 42

**Note:** A “HOME” key has been added to the cleaning screens to allow the user to easily exit the cleaning screens and return to the Beverage Select screen.

4. Prepare a 2.5 gallon (9.5 liters) pail of an approved cleaning solution.
5. Prepare a 2.5 gallon (9.5 liters) pail of an approved sanitizing solution containing an active chlorine concentrate of 100 - 200 PPM.
6. Fill the spray bottle and the squeeze bottle with the cleaning solution.
7. Take the prepared pails and bottles to the machine.
8. Place a blender pitcher in the dispensing area. (See Figure 43.)

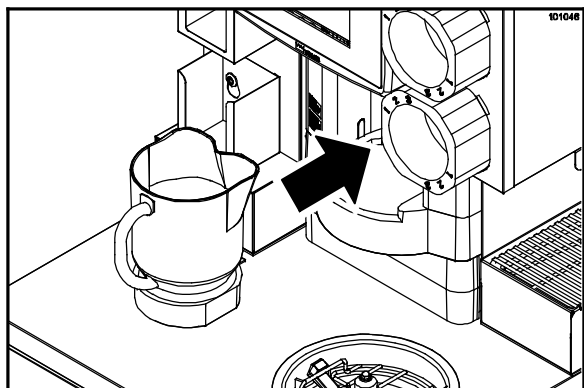

Figure 43

9. Remove the ice hopper cover. Scoop out as much ice as possible, using a clean, sanitized ice scoop. (See Figure 44.)



**Use caution when removing ice near the shaver blade area.** Failure to follow this instruction could result in personal injury from blade contact.

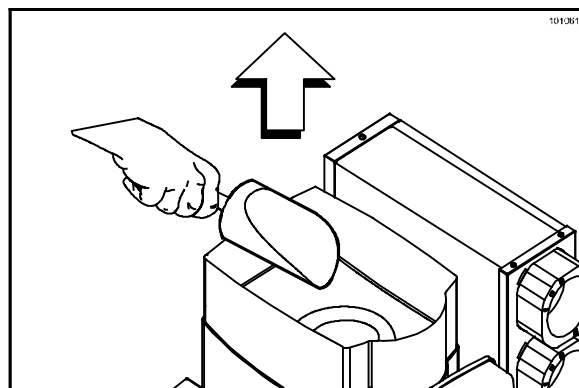

Figure 44

10. Reinstall the ice hopper cover. (See Figure 45.)

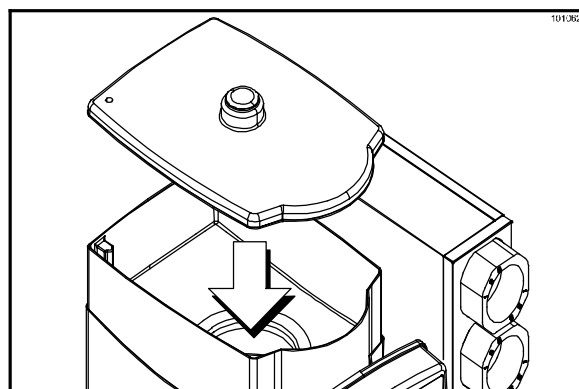

Figure 45

11. Press the ICE key until all remaining ice has dispensed into the blender pitcher.

12. Remove the blender pitcher and discard the ice into the back sink. (See Figure 46.)

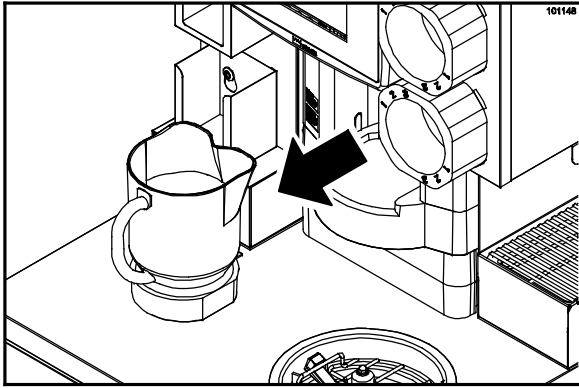

Figure 46

13. Remove the ice hopper and cover. Take them to the 3-compartment sink for cleaning. (See Figure 47.)

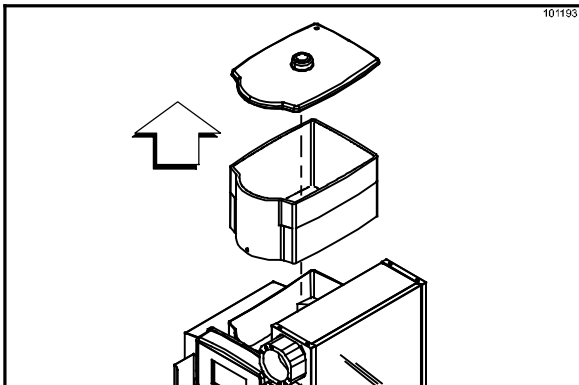

Figure 47

14. Remove the following parts and take them to the 3-compartment sink for cleaning: blender pitchers, splash guard, ice chute, skirt, syrup rail, rinse station assembly (grate, strainer, and actuator), pitcher drying station (pitcher stand grate and drip pan), lid holders, whipped cream holder, and mix cabinet drip pan. (**Note:** The bottom product bins and shelves must be removed in order to remove the mix cabinet drip pan.) (See Figure 48.)

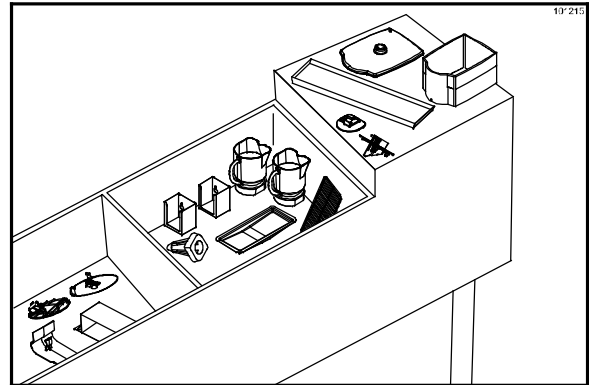

Figure 48

15. Install the whipped cream cover over the opening on the machine. (See Figure 49.)

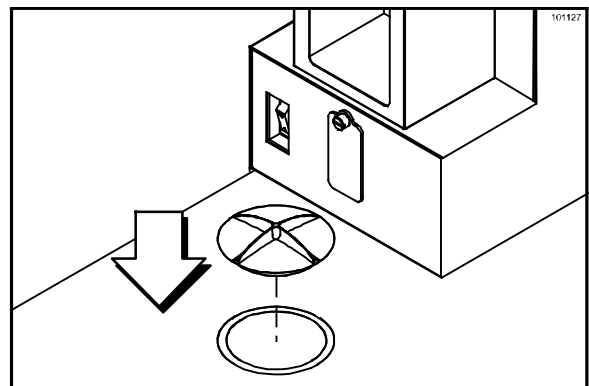

Figure 49

16. Wash the parts in a hot, approved cleaning solution. **Note: Do not place the parts in the power soaker sink or dishwasher.**



**CAUTION:** Use care when washing the blender pitchers. **DO NOT touch the pitcher blades with your hands.** Failure to follow this instruction may result in personal injury from blade contact.

**International Units Only:** Use supplied brush to clean the guarded pitcher. Make sure to thoroughly clean the top, bottom, and all points where the guard contacts the pitcher cup.

**Note:** If there is a film build-up on the inside of the blender pitchers, place the required amount of approved blender pitcher cleaner into the pitchers. Fill the pitchers with **hot** water and allow them to soak for 5 - 10 minutes.



Use care when filling the pitchers to avoid a scald injury. (See Figure 50.)

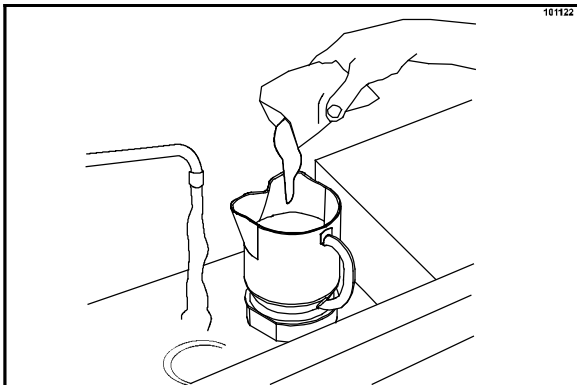

Figure 50



After 5 - 10 minutes, wear protective gloves and use a no-scratch pad to remove residual soil. Discard the cleaning solution.

17. Rinse the parts in cool, clean water.
18. Sanitize the parts in an approved sanitizing solution containing an active chlorine concentrate of 100 - 200 PPM. If required by your Local code, rinse with clean water.
19. Place the following parts on a clean, dry surface to air dry overnight: ice hopper, ice hopper cover, blender pitchers, splash guard, ice chute, rinse station assembly (grate, actuator, and strainer), pitcher drying station (grate and drip pan), skirt, syrup rail, lid holders, whipped cream holder, and mix cabinet drip pan. (See Figure 51.)

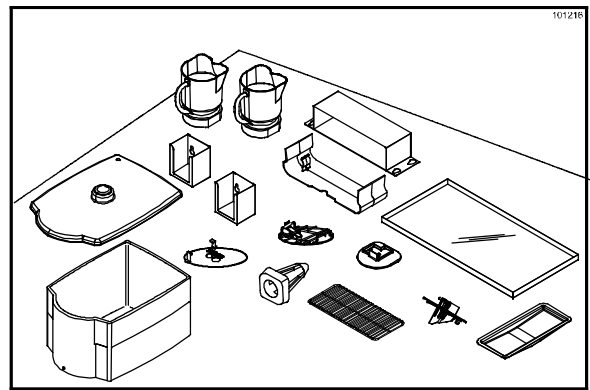

Figure 51

20. Using the squeeze bottle filled with cleaning solution, flush the dispensing area. (See Figure 52.)

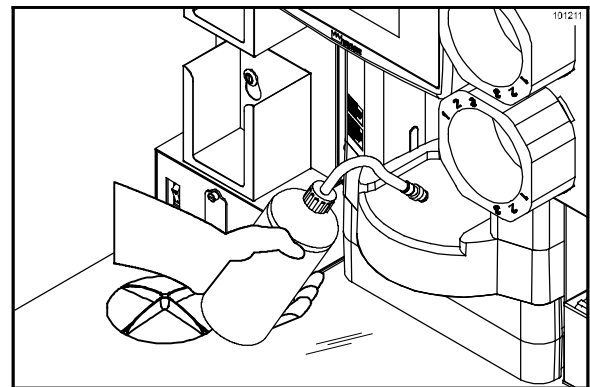

Figure 52



21. Using the spray bottle of cleaning solution and the spout brush, brush clean the dispensing head area.

Repeatedly dip the mix tube brush into the pail of cleaning solution and brush clean the dispenser head openings.  
(See Figure 53.)

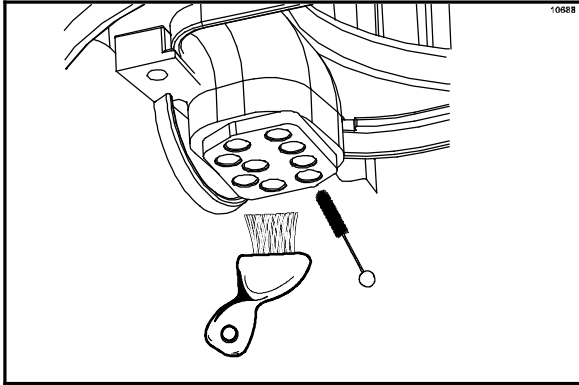

Figure 53

22. If required by your Local code, repeat the previous step, using clean water.
23. Repeatedly dip the spout brush into the pail of cleaning solution and very carefully brush clean the shaver assembly blade and surrounding area.  
(See Figure 54.)

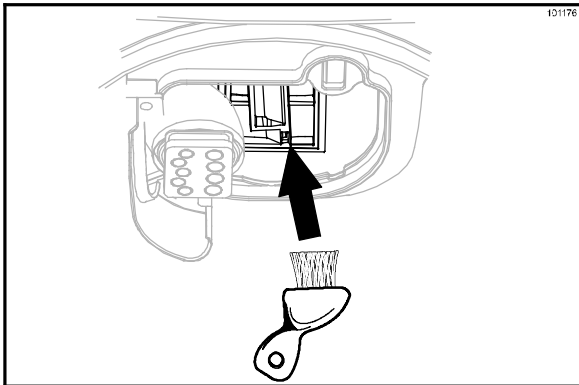

Figure 54

24. If required by your Local code, repeat the previous step, using clean water.

25. Using the squeeze bottle of cleaning solution, thoroughly flush the shaver assembly blade and surrounding area.  
(See Figure 55.)

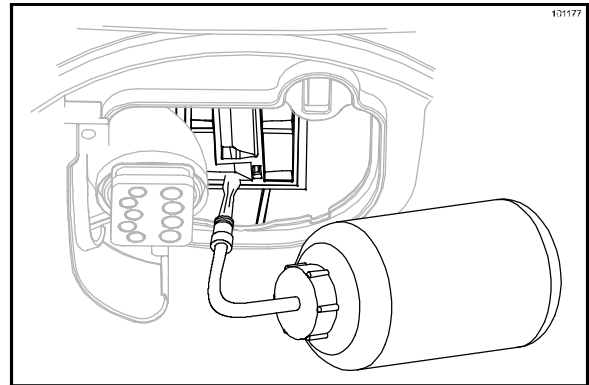

Figure 55

26. If required by your Local code, repeat the previous step, using clean water.
27. Brush clean the rinse station, using the squeeze bottle of cleaning solution and the spout brush. Pay particular attention to the rinser head and the drain area.  
(See Figure 56.)

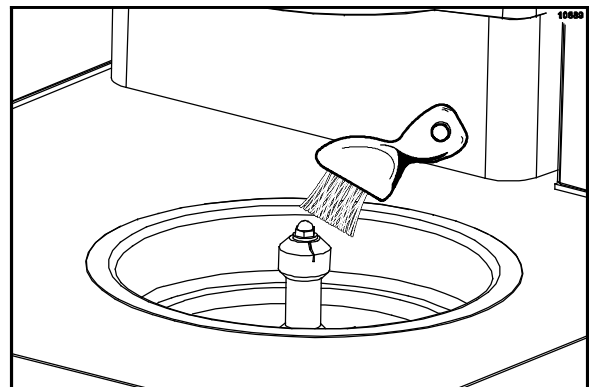

Figure 56

28. Using the squeeze bottle filled with cleaning solution, thoroughly flush the rinse station area. (See Figure 57.)

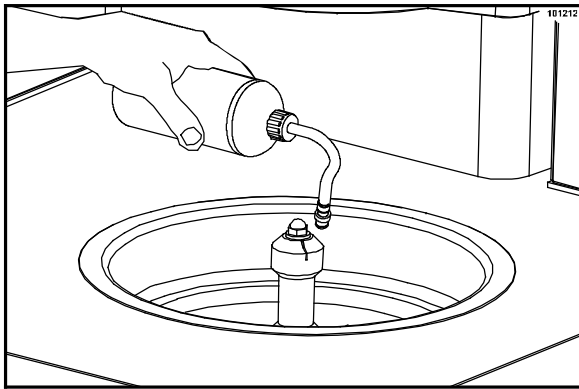

Figure 57

29. Fill the spray bottle and the squeeze bottle with an approved sanitizing solution containing an active chlorine concentrate of 100 - 200 PPM.
30. **Repeat steps 20 - 28, using the sanitizing solution.**
31. Take the whipped cream holder cover to the 3-compartment sink. Wash, rinse, sanitize, and then dry the cover with a single-use sanitized towel. Reinstall the cover over the opening on the machine. (See Figure 58.)

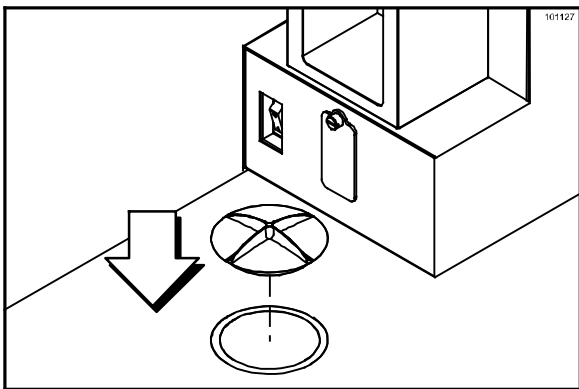

Figure 58

**Note: For units equipped with a square whipped cream holder opening:**  
Dry the whipped cream holder with a single-use sanitized towel. Place the cover on the holder. Install the whipped cream holder and cover on the unit.

32. Use clean, sanitized towels and the spray bottle of sanitizing solution to remove any residual soils or cleaners. Wipe down the interior of the refrigerated cabinet, paying particular attention to the gaskets and edges of the cabinet door. (See Figure 59.)

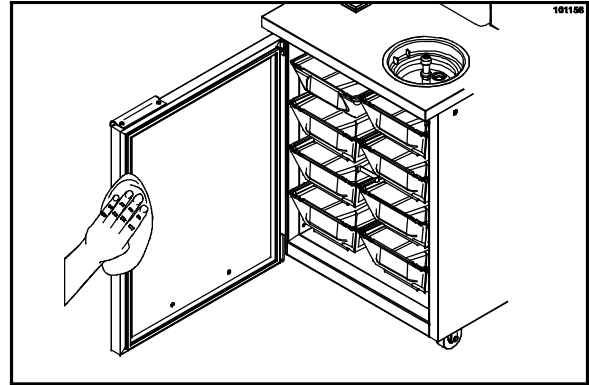

Figure 59

**IMPORTANT: DO NOT** use a screwdriver or other sharp tool to clean the gasket grooves. This will damage the gaskets.

33. Using clean, sanitized towels and the spray bottle of sanitizing solution, wipe the exterior of the machine and the blend center, including the dispensing head and the rinse station. Discard the used towels. (See Figure 60.)

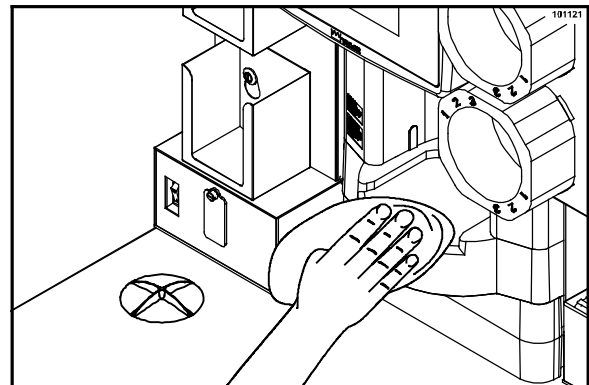

Figure 60

## WEEKLY CLEANING PROCEDURES

This procedure must be done at the close of business.

**Note:** When sanitizer is used, it must always have a contact time of 5 minutes. Afterward, if required by your Local code, rinse with clean water.

1. From the Beverage Selection screen, press the MENU key. (See Figure 61.)

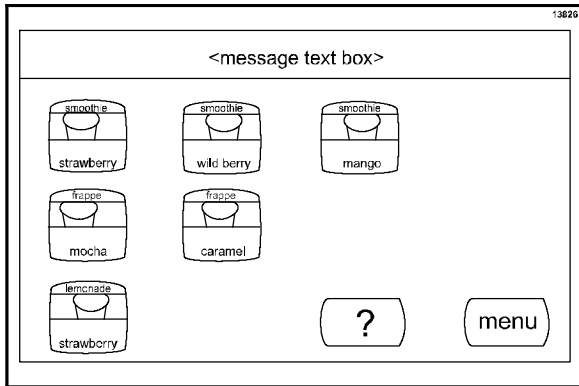

Figure 61

2. From the Main Menu screen, press the CLEANING key. (See Figure 62.)

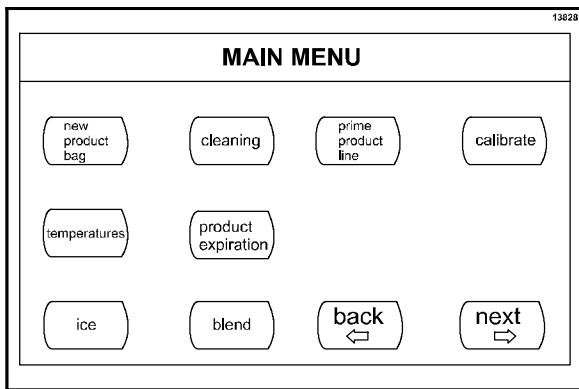

Figure 62

3. Press the WEEKLY key. (See Figure 63.)

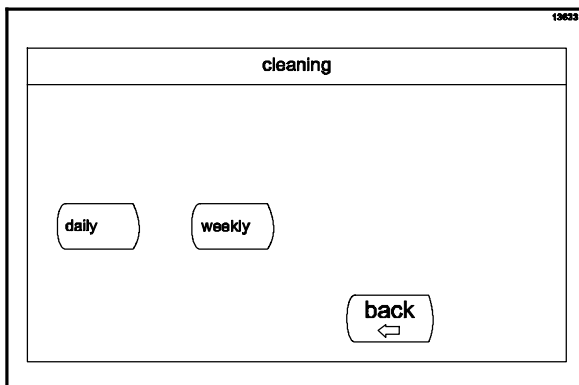

Figure 63

**Note:** A "HOME" key has been added to the cleaning screens to allow the user to easily exit the cleaning screens and return to the Beverage Select screen.

4. Using the sink proportioner, prepare an approved cleaning solution in the 5 gallon Cleaning Solution pail (pail #1). Fill the pail to the labeled level. (See Figure 64.)

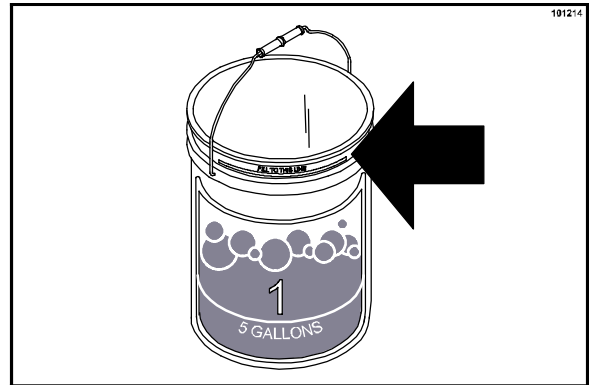

Figure 64

5. Fill the 5 gallon Rinse pail (pail #2) with warm water, to the labeled level.
6. Prepare an approved sanitizing solution containing an active chlorine concentrate of 100 - 200 PPM in the 5 gallon Sanitizing Solution pail (pail #3). Fill the pail to the labeled level.
7. Place a blender pitcher in the dispensing area. (See Figure 65.)

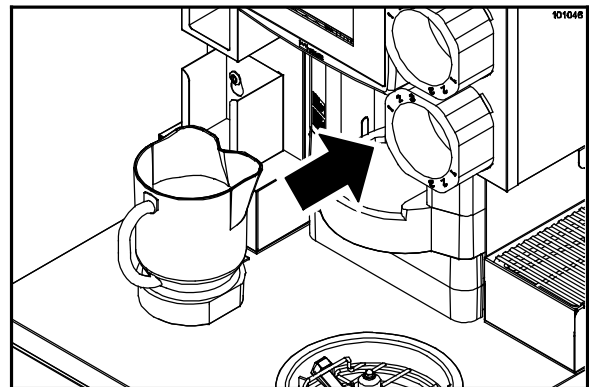

Figure 65

8. Remove the ice hopper cover. Scoop out as much ice as possible, using a clean, sanitized ice scoop. (See Figure 66.)



**Use caution when removing ice near the shaver blade area.** Failure to follow this instruction could result in personal injury from blade contact.

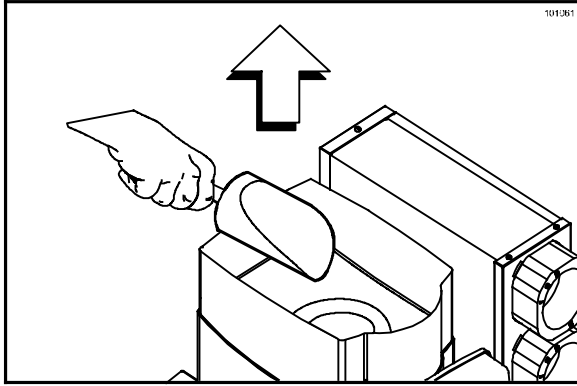

Figure 66

9. Reinstall the ice hopper cover. (See Figure 67.)

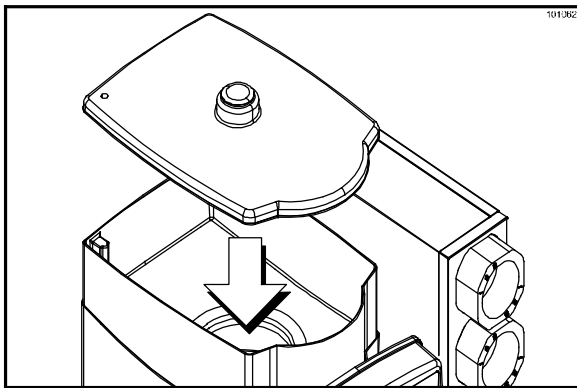

Figure 67

10. Press the ICE key until all remaining ice has dispensed into the blender pitcher.
11. Remove the blender pitcher and discard the ice into the back sink. (See Figure 68.)

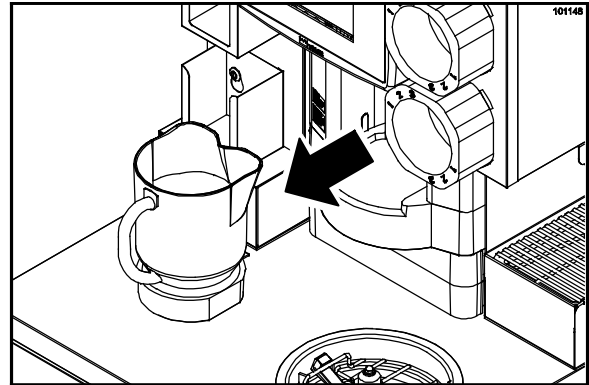

Figure 68

12. Remove the splash guard, ice chute, and ice hopper assembly. Take them to the 3-compartment sink for cleaning. (See Figure 69.)

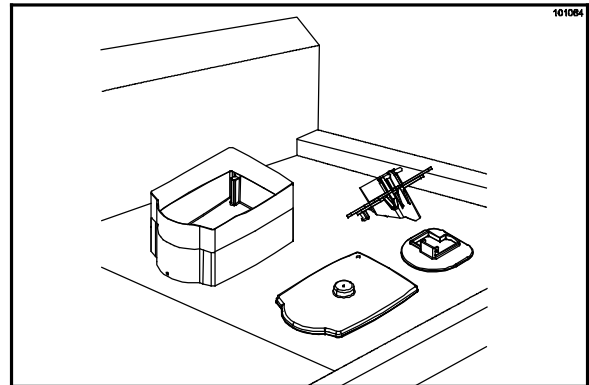

Figure 69

- Remove the following parts and take them to the 3-compartment sink for cleaning: blender pitchers, skirt, syrup rail, rinse station assembly (grate, strainer, and actuator), pitcher drying station (grate and drip pan), lid holders, whipped cream holder and whipped cream holder cover. (See Figure 70.)

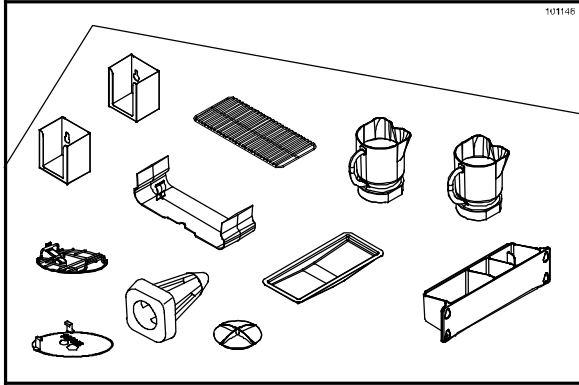

Figure 70

- Remove the product bins. (See Figure 71.)

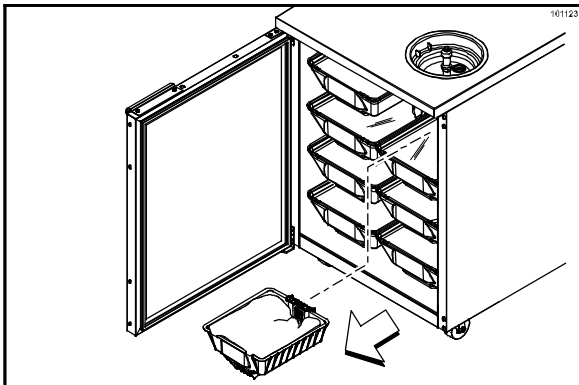

Figure 71

- Remove the product bags from the product bins. Immediately place all partially used product bags in the walk-in cooler.

**Note:** To remove the product bag from the bin, move the product bin slide to the “open” position by (1) pulling the slide slightly away from the bin and (2) up, until it stops. (See Figure 72.)

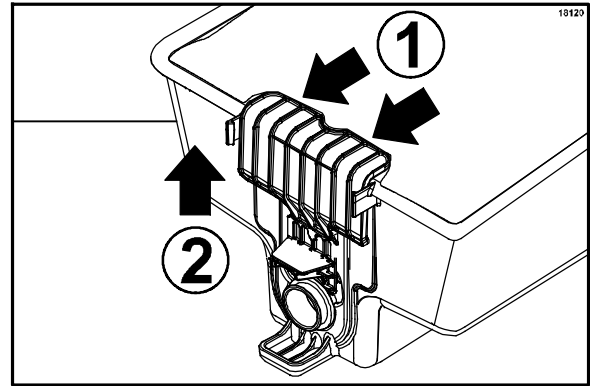

Figure 72

- Take the product bins to the 3-compartment sink for cleaning.
- Remove the product bin shelves and the mix cabinet drip pan. Take them to the 3-compartment sink for cleaning. (See Figure 73.)

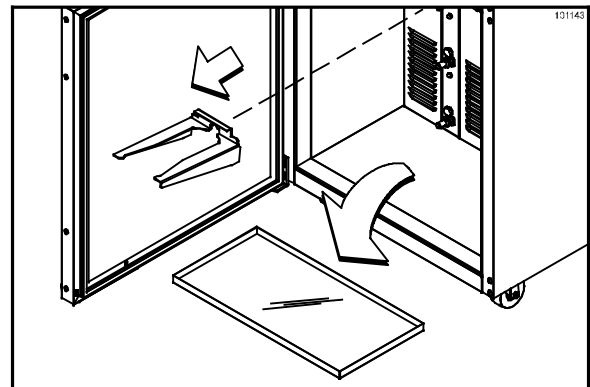

Figure 73

- Wash the parts in a hot, approved cleaning solution. **Note: Do not place the parts in the power soaker sink or dishwasher.** (See Figure 74.)

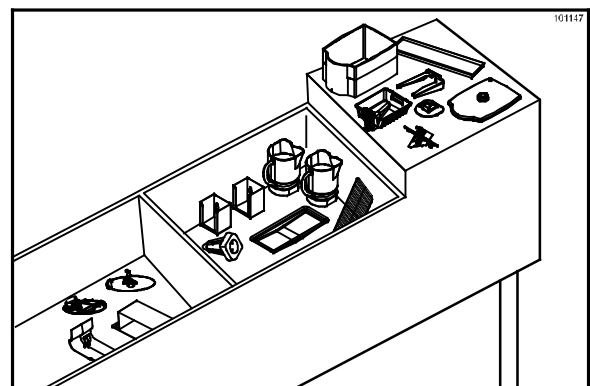

Figure 74



**CAUTION: Use care when washing the blender pitchers. DO NOT touch the pitcher blades with your hands.** Failure to follow this instruction may result in personal injury from blade contact.

**Note:** If there is a film build-up on the inside of the blender pitchers, place the required amount of approved blender pitcher cleaner into the pitchers. Fill the pitchers with **hot** water and allow them to soak for 5 - 10 minutes.



Use care when filling the pitchers to avoid a scald injury. (See Figure 75.)

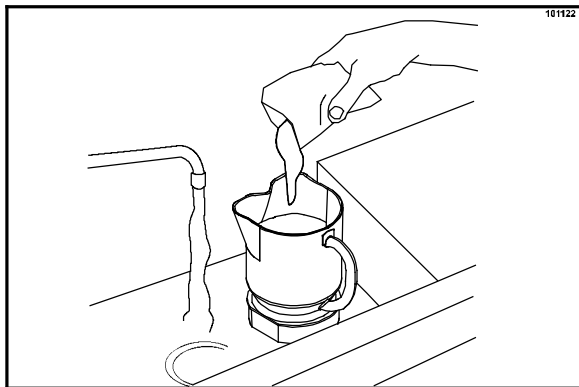

Figure 75



After 5 - 10 minutes, wear protective gloves and use a no-scratch pad to remove residual soil. Discard the cleaning solution.

**International Units Only:** Use supplied brush to clean the guarded pitcher. Make sure to thoroughly clean the top, bottom, and all points where the guard contacts the pitcher cup.

19. Rinse the parts in cool, clean water.
20. Sanitize the parts in an approved sanitizing solution containing an active chlorine concentrate of 100 - 200 PPM. If required by your Local code, rinse with clean water.

21. Dry the whipped cream holder cover with a single-use sanitized towel. Install the cover over the opening on the machine. (See Figure 76.)

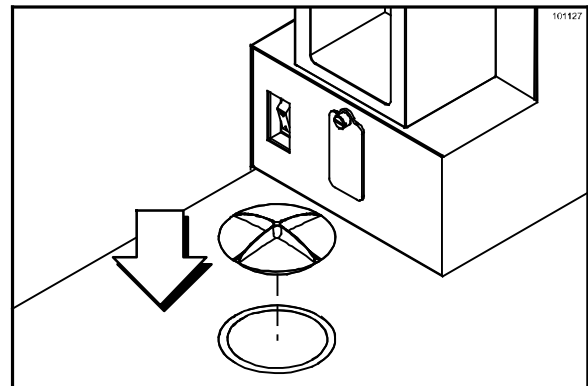

Figure 76

**Note: For units equipped with a square whipped cream holder opening:**

Dry the whipped cream holder with a single-use sanitized towel. Place the cover on the holder. Install the whipped cream holder and cover on the unit.

22. Place the blender pitchers, skirt, syrup rail, pitcher drying station (grate and drip pan), lid holders, and whipped cream holder on a clean, dry surface to air dry overnight. (See Figure 77.)

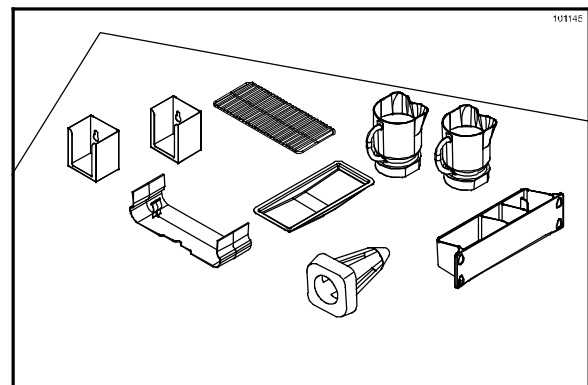

Figure 77

23. Using the squeeze bottle filled with cleaning solution, flush the ice shaver assembly while brushing with the large white ice hopper brush. (See Figure 78.)

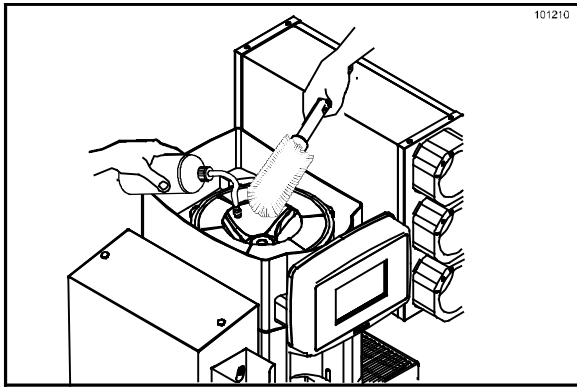

Figure 78

24. Using the squeeze bottle of cleaning solution, flush inside, outside, and under the ice shaver assembly, thoroughly covering all surfaces. (See Figure 79.)

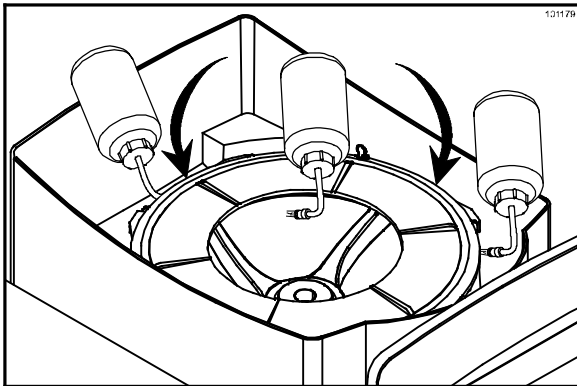

Figure 79

25. Thoroughly flush cleaning solution under the lip of the ice shaver assembly plastic cover. Make sure the solution is applied in a complete 360° circle. (See Figure 80.)

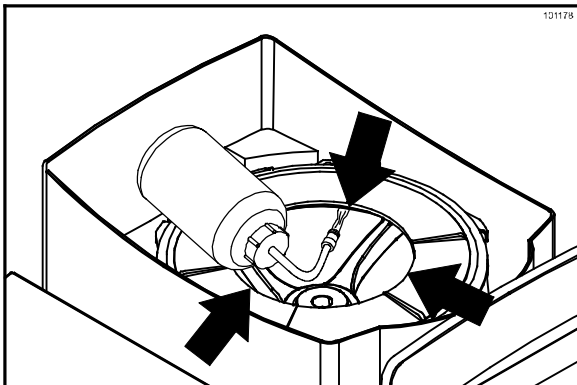

Figure 80

26. Repeat the ice shaver assembly cleaning steps, using a sanitizing solution containing an active chlorine concentrate of 100 - 200 PPM.

27. Wearing protective gloves, loosen the wing nut from the rear panel of the box that supports the lid holders. (See Figure 81.)

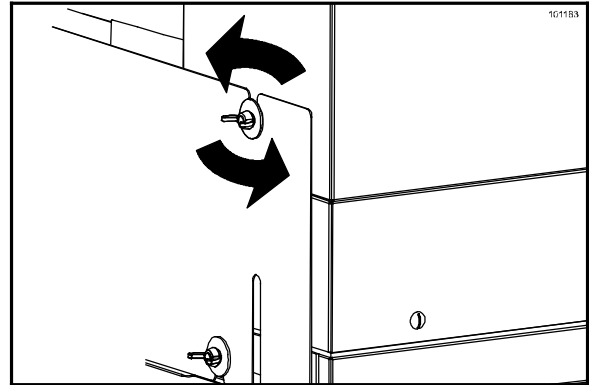

Figure 81

28. Remove the box by sliding it forward. Place the box on a clean, stable surface. (See Figure 82.)

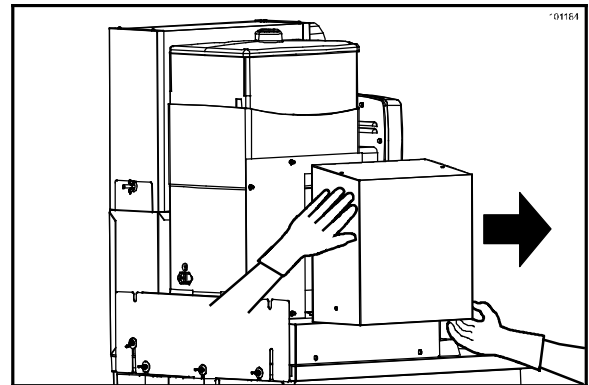

Figure 82

29. Using clean, sanitized towels and the spray bottle of sanitizing solution, wipe the black tubing to remove any potential buildup. Do not allow sanitizer to drip onto the surface below. (See Figure 83.)

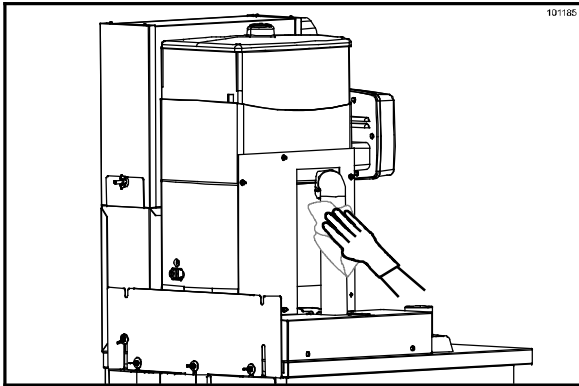

Figure 83

30. Dry the area with a single-use sanitized towel.
31. Reinstall the lid holder box by positioning the locking notch opening in the bottom of the box over the locking notch. Push the box back until the locking notch securely engages the opening and stops the box movement. Verify proper installation by attempting to lift the box up. If the box is properly installed, the box will not lift up. (See Figure 84.)

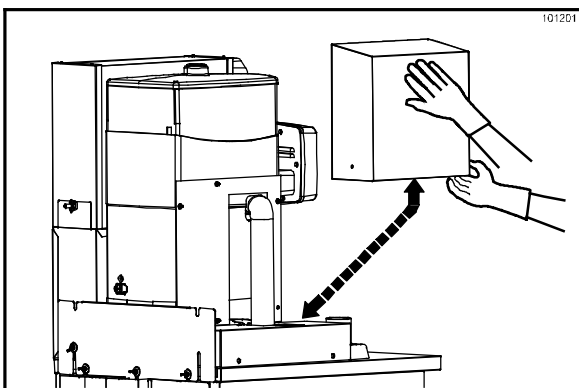

Figure 84

32. Tighten the wing nut on the rear panel of the box.

33. Using sanitizing solution and a clean, sanitized towel, clean the syrup fittings at the back of the cabinet to remove any dried-on residue. (See Figure 85.)

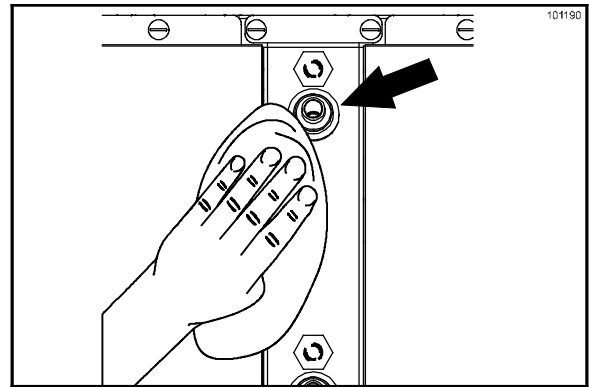

Figure 85

34. Place the three pails on the floor in front of the machine. The pail marked "1", containing the cleaning solution, will be used first. (See Figure 86.)

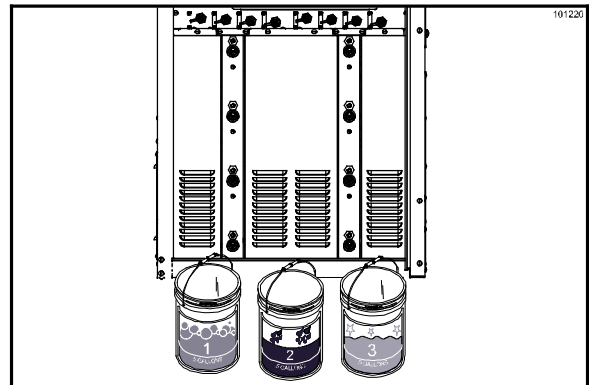

Figure 86

35. Install cleaning tubes onto all inlet fittings. Place the other end of the cleaning tubes into the pail of cleaning solution. (See Figure 87.)

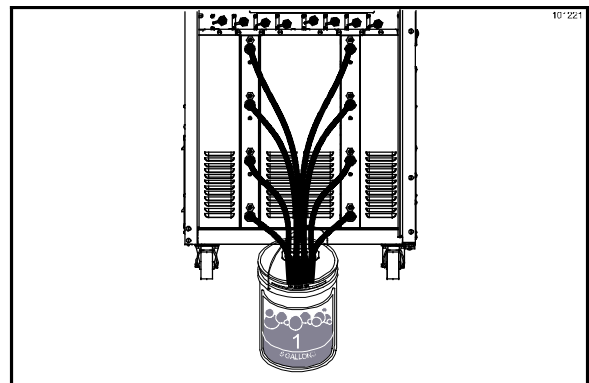

Figure 87



36. Reinstall the rinse station assembly (strainer, grate, and actuator). (See Figure 88.)

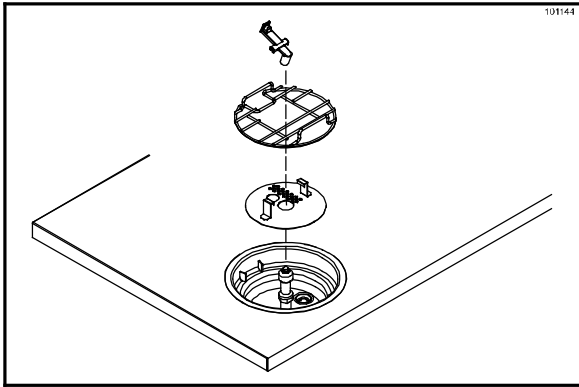

Figure 88

37. Slide the cleaning hose adaptor onto the dispensing head. Wedge the other end of the line into the rinse station grate. (See Figure 89.)

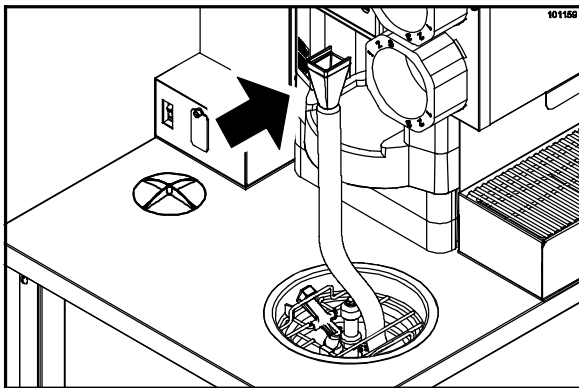

Figure 89

38. Turn the CO2 valves to the “down/on” position to open ALL pumps. (See Figure 90.)

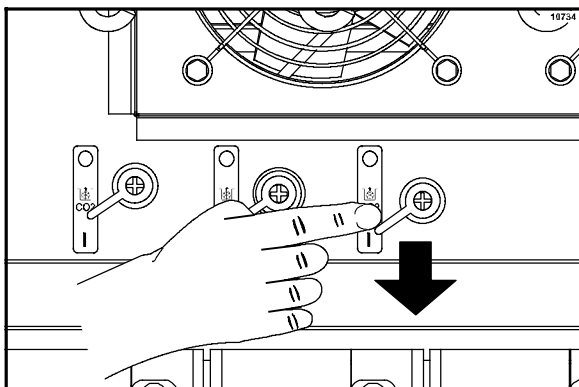

Figure 90

**Note:** Some markets use compressed air instead of CO2.

39. Press the NEXT key to start the cleaning cycle. One at a time, the cleaning solution will pump through each product line.

A bar graph screen will illustrate the cleaning progress for each product line. (See Figure 91.)

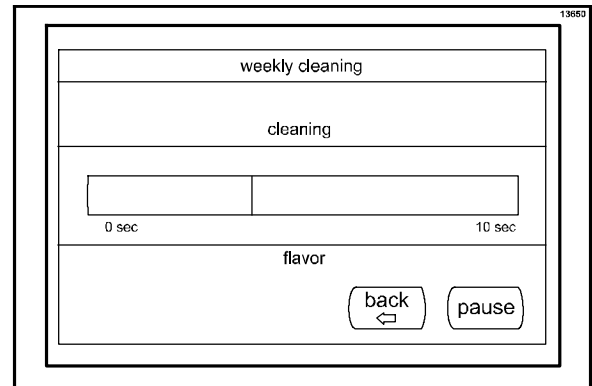

Figure 91

**Note:** If the drain is not draining fast enough or if the operator needs to leave the machine for awhile, the PAUSE key can be used to stop and restart the process. If the PAUSE key is pressed, a bar graph screen will illustrate the drain pause progress for each product line. (See Figure 92.)

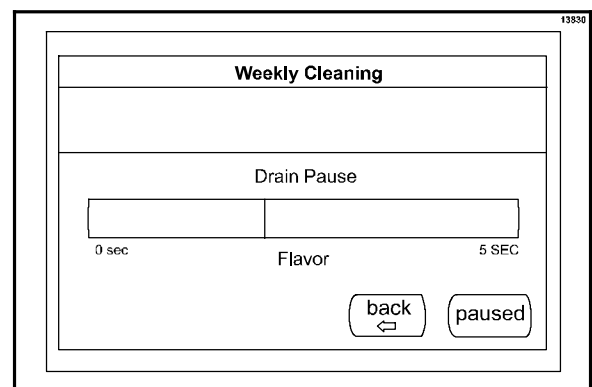

Figure 92

40. Remove the free end of the cleaning tubes from the pail of cleaning solution and place them into the pail of rinse water. (See Figure 93.)

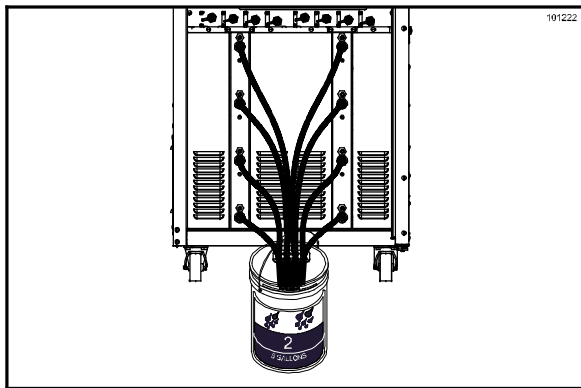

Figure 93

41. Press the NEXT key to start the rinse cycle. The unit will automatically start and stop pumping rinse water through the systems. (See Figure 94.)

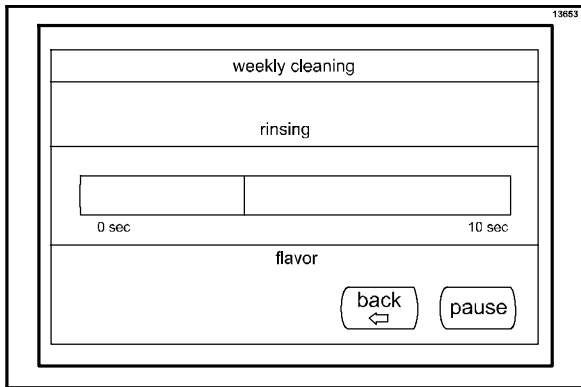

Figure 94

**Note:** The PAUSE key can be used to stop and restart the process.

42. Remove the free end of the cleaning tubes from the pail of rinse water and place them into the pail of sanitizing solution. (See Figure 95.)

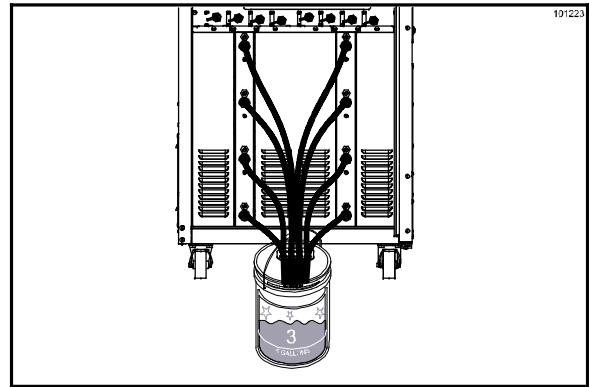

Figure 95

43. **Perform this step if required by your market. Otherwise, proceed to step 44.** Upon completion of the rinse cycle, discard the remaining rinse water. Sanitize and refill the pail with clean water for a final rinse cycle after completion of the sanitizing cycle.
44. Press the NEXT key to start the sanitizing cycle. The unit will automatically start and stop pumping sanitizing solution through the systems and into the rinser bowl. (See Figure 96.)

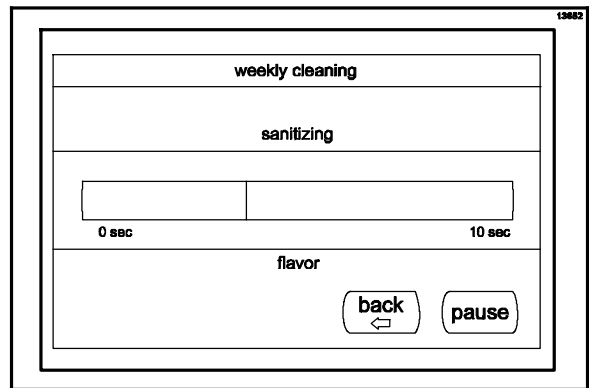

Figure 96

**Note:** The PAUSE key can be used to stop and restart the process.

45. After the sanitizing solution stops pumping through the systems, it will soak for 60 seconds. (See Figure 97.)

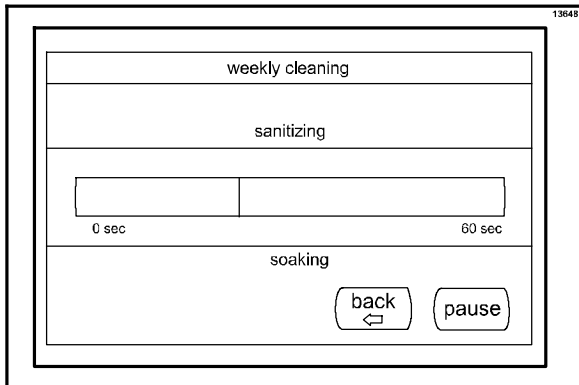

Figure 97

46. **Perform this step if required by your market. Otherwise proceed to step 47.** Upon completion of the sanitizing cycle, place the free end of the cleaning tubes into the second pail of rinse water. Press the NEXT key to start the final rinse cycle. The unit will automatically start and stop pumping rinse water through the systems.

47. Remove the cleaning tubes from the pail and lay them across the rim of the pail. Keep the cleaning hose adaptor connected to the dispensing head. (See Figure 98.)

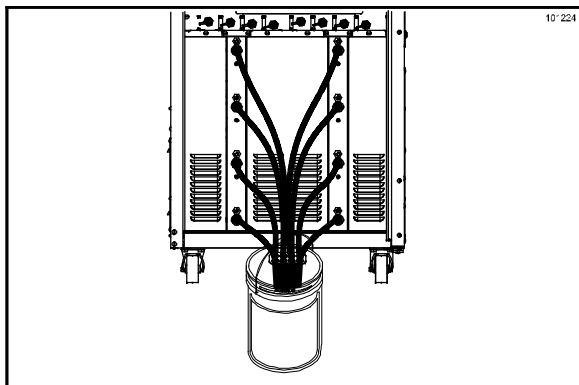

Figure 98

48. Press the NEXT key to start the purge cycle. (See Figure 99.)

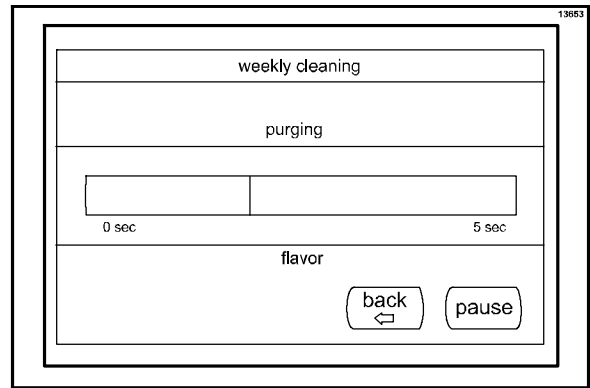

Figure 99

**Note:** The PAUSE key can be used to stop and restart the process.

49. Remove the cleaning hose adaptor and place it in an empty pail. (See Figure 100.)

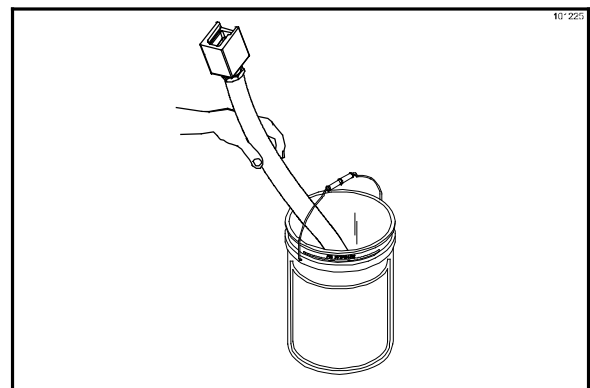

Figure 100

50. Remove the cleaning tubes from the inlet fittings and place them in an empty pail. (See Figure 101.)

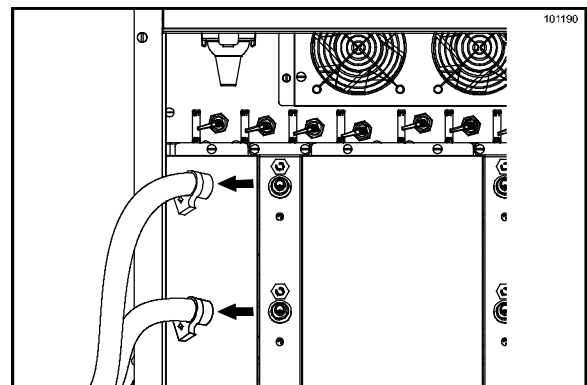

Figure 101

- Close the unused pumps by turning the CO2 valves to the “up/off” position. (See Figure 102.)

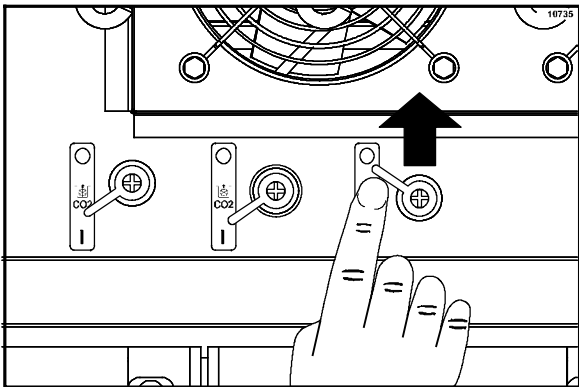

Figure 102



**CAUTION:** Failure to close the valves to unused pumps allows CO2 to escape. In high concentrations, CO2 is toxic to humans and may cause asphyxiation in confined areas.

- Wipe the inside of the cabinet door and inlet fittings, using an approved sanitizing solution containing an active chlorine concentrate of 100 - 200 PPM and a clean, sanitized towel. (See Figure 103.)

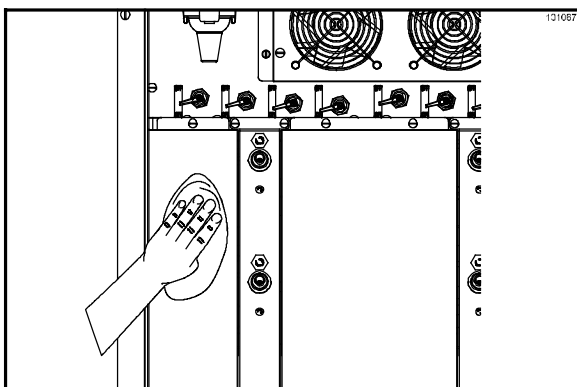

Figure 103

- Using the spray bottle of cleaning solution and the spout brush, brush clean the dispensing head area.

Repeatedly dip the mix tube brush into the pail of cleaning solution and brush clean the dispenser head openings. (See Figure 104.)

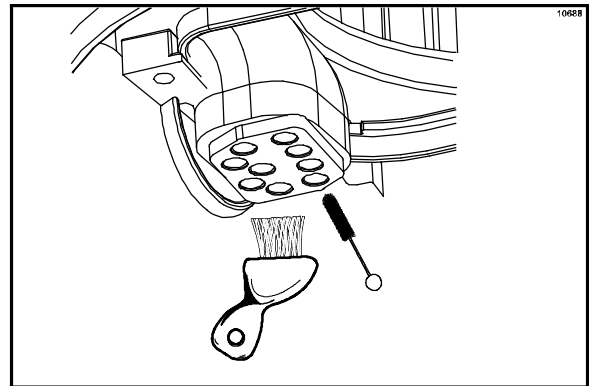

Figure 104

- Repeat the previous step, using sanitizing solution.
- Reinstall the ice hopper and the ice hopper cover. (See Figure 105.)

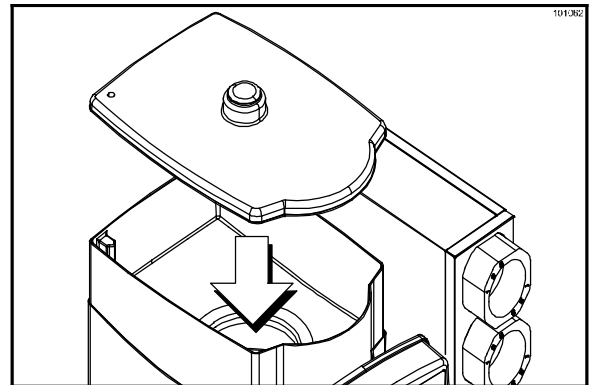

Figure 105

- Lightly lubricate the inlet fittings, using an approved food grade lubricant (example: Taylor Lube). Make sure no lubricant enters the fittings. (See Figure 106.)

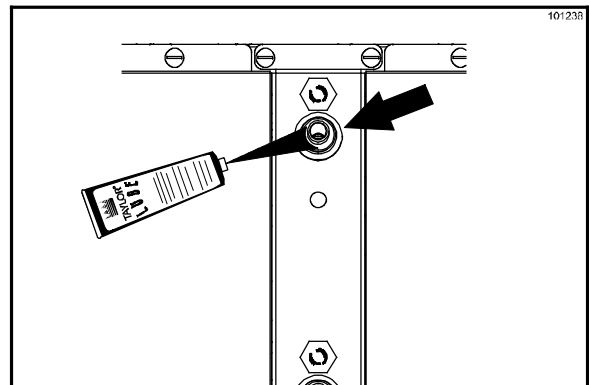

Figure 106

57. Install the mix cabinet drip pan.  
(See Figure 107.)

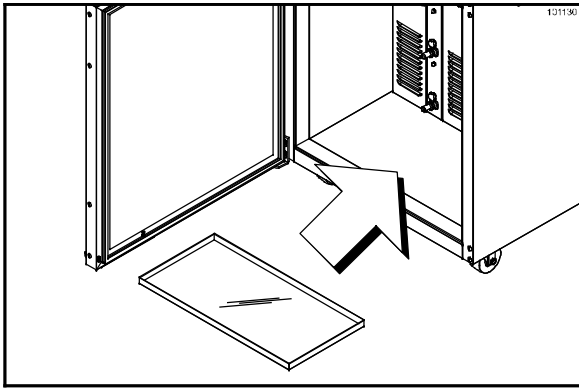

Figure 107

58. Install the product bin shelves.  
(See Figure 108.)

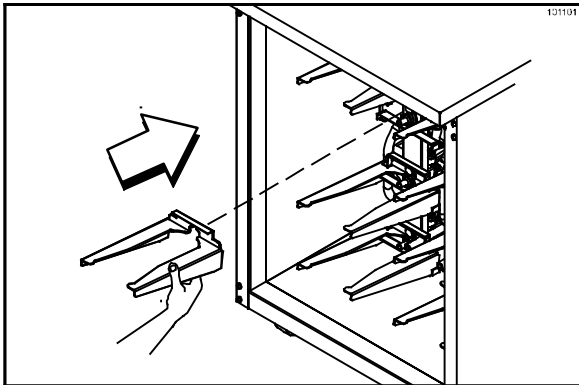

Figure 108

59. Place the bag of product into the base of the product bin with the **spout facing down**. (See Figure 109.)

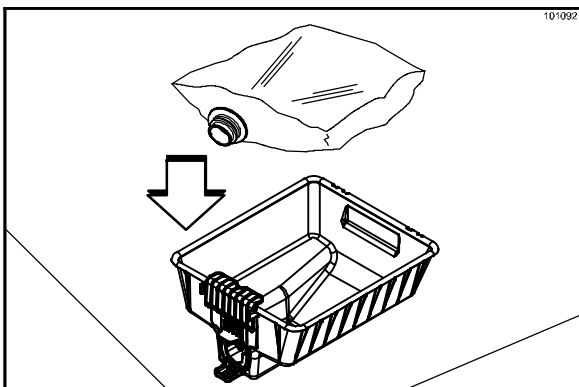

Figure 109

60. Slide the product bag spout into the slot of the product bin.  
**IMPORTANT: Position the rear groove of the product bag spout into the slot of the product bin. Lock the spout into position by pushing down on the product bin slide until it snaps in place.**  
(See Figure 110.)

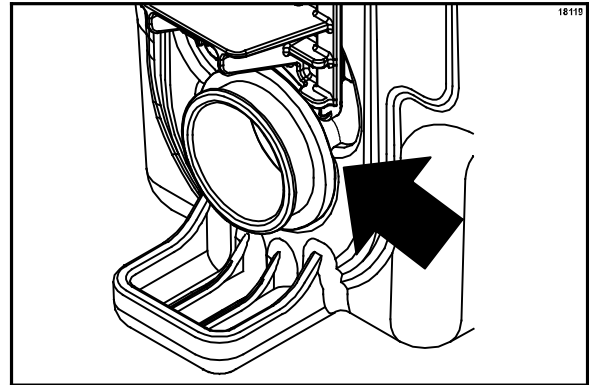

Figure 110

**IMPORTANT: Make sure the product bag is not pinched in the bin slot.**

61. Arrange the product bag so it is flat and spread out in the bin. Attach the rear of the bag over the two bin hooks.  
(See Figure 111.)

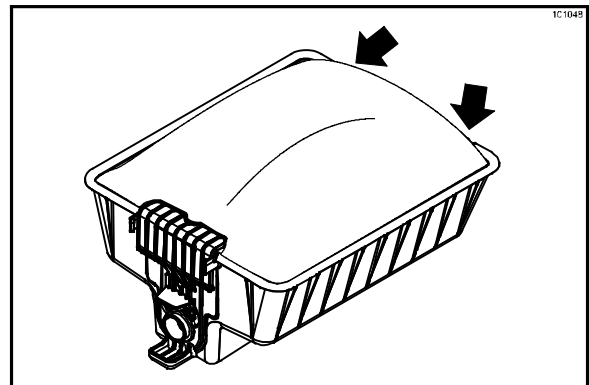

Figure 111

62. Place each product bin in its proper position. The product locations are labeled inside the refrigerated cabinet. Make sure the bag spout slides over the product tube. (See Figure 112.)

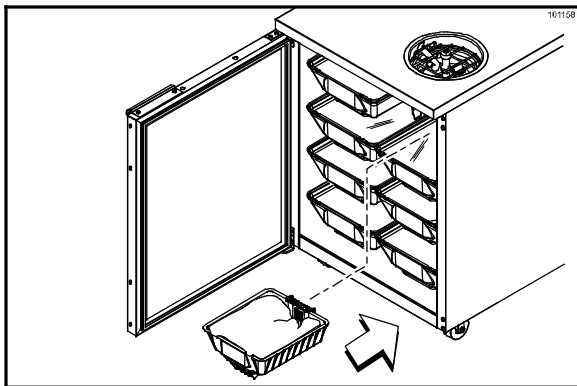

Figure 112

63. Install the ice chute and the splash guard. (See Figure 113.)

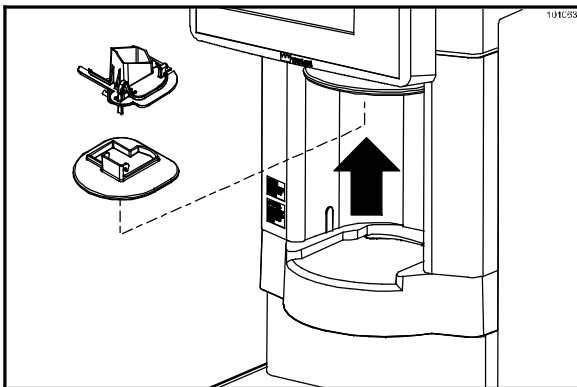

Figure 113

64. Place a blender pitcher in the dispensing area. (See Figure 114.)

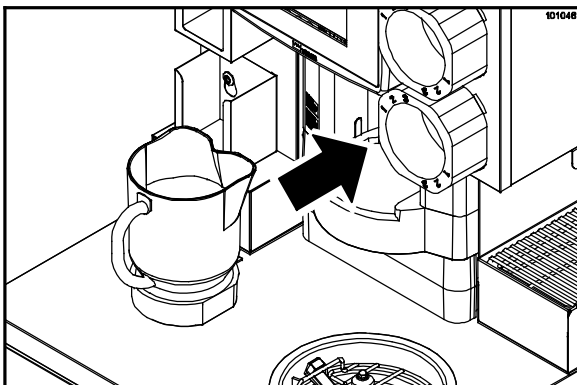

Figure 114

65. Press the NEXT key to prime the product lines. The PAUSE key can be used to stop and restart the process. (See Figure 115.)

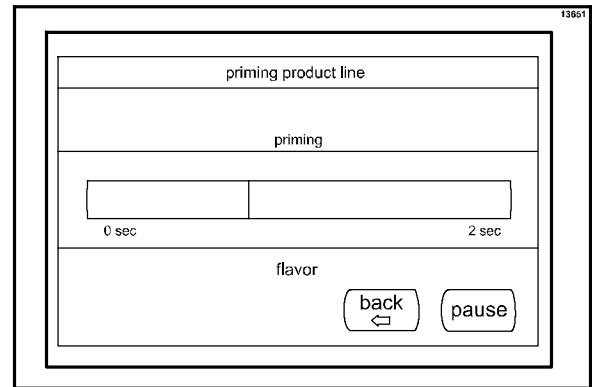

Figure 115

66. After the last product line has primed, press the NEXT key.
67. Remove the blender pitcher and discard the product into the back sink. **Do not pour the product down the rinse station drain.** (See Figure 116.)

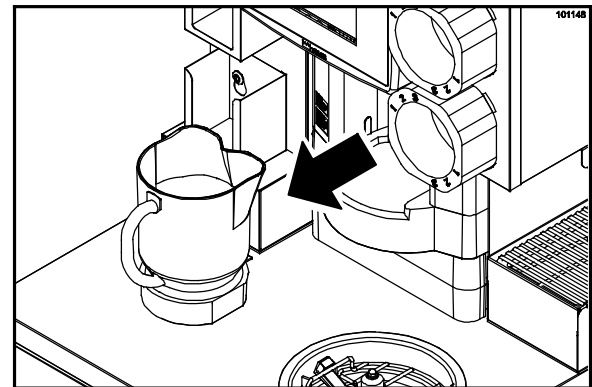

Figure 116

68. Using the squeeze bottle of cleaning solution, thoroughly flush the dispensing drain area. (See Figure 117.)

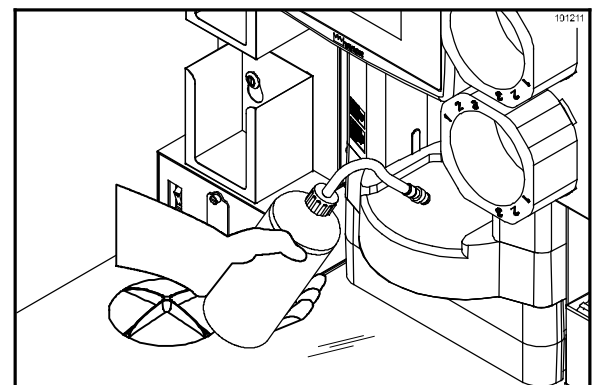

Figure 117

69. Remove the rinse station assembly. Brush clean the rinse station, using the spray bottle of cleaning solution and the spout brush. Pay particular attention to the rinser head and the drain area. (See Figure 118.)

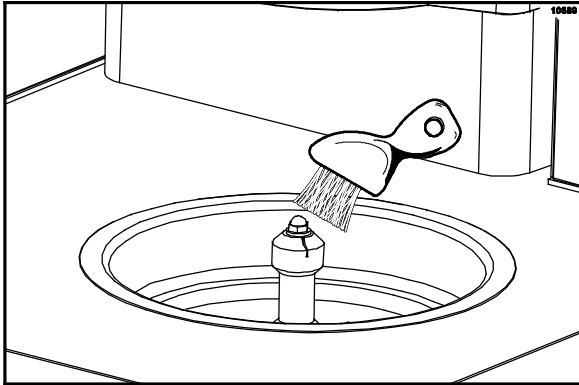

Figure 118

70. Reinstall the rinse station assembly. Using the squeeze bottle of cleaning solution, thoroughly flush the rinser head and rinse station area. (See Figure 119.)

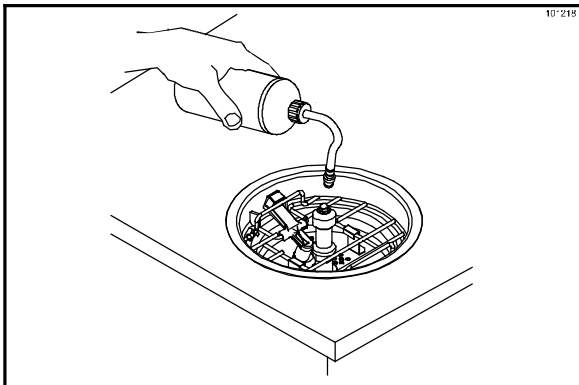

Figure 119

71. Repeat steps 66 - 68, using sanitizing solution.

72. Using clean, sanitized towels and the spray bottle of sanitizing solution, wipe down the interior of the refrigerated cabinet to remove any residual soils or cleaners. Pay particular attention to the gaskets and edges of the cabinet door. (See Figure 120.)

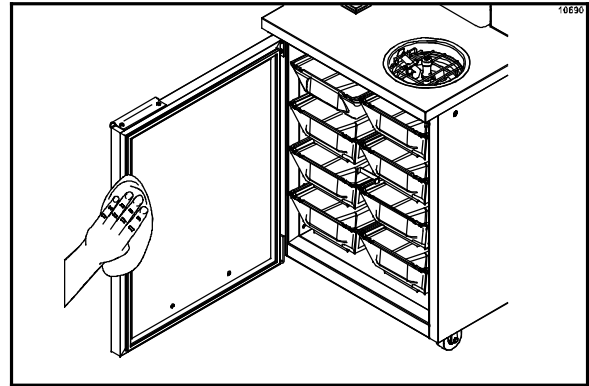

Figure 120

**IMPORTANT:** DO NOT use a screwdriver or other sharp tool to clean the gasket grooves. This will damage the gaskets.

73. Using clean, sanitized towels and the spray bottle of sanitizing solution, wipe the exterior of the machine and the blend center, including the dispensing head and the rinse station. Discard the used towels. (See Figure 121.)

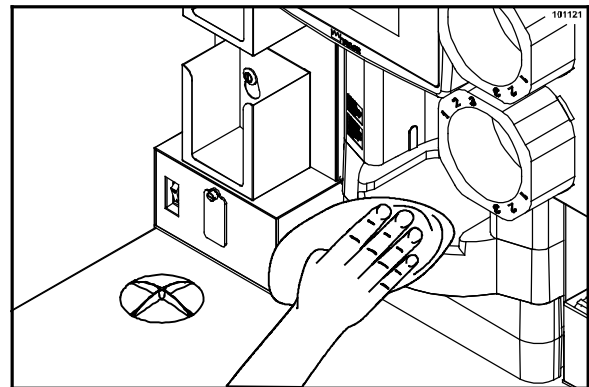

Figure 121

74. Slowly pour two full pitchers of hot water from the back sink into the rinse station drain.



**CAUTION: Water temperature must not exceed 140°F (60°C).** (See Figure 122.)

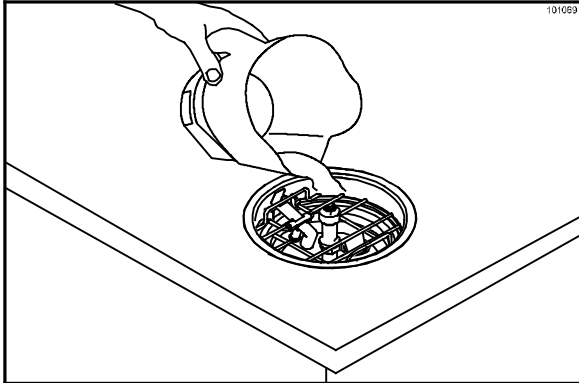

Figure 122



**CAUTION: Wear eye protection before performing the following steps.** Failure to follow this instruction may result in drain cleaner splashing into the eyes. (Please refer to the approved drain cleaner MSDS for recommendations regarding proper Personal Protection Equipment [PPE].)

75. Prepare the drain cleaning solution according to the manufacturer's instructions.
76. Carefully purge a small amount of solution from the dispenser into the utility sink. This helps prevent “sputtering” of solution and possible splashing back onto clothing or eyes. (See Figure 123.)

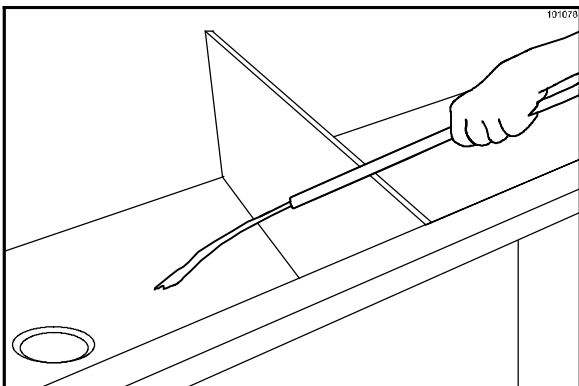

Figure 123

77. Carefully spray the proper amount of drain cleaning solution into the blender dispensing area drain hole. (See Figure 124.)

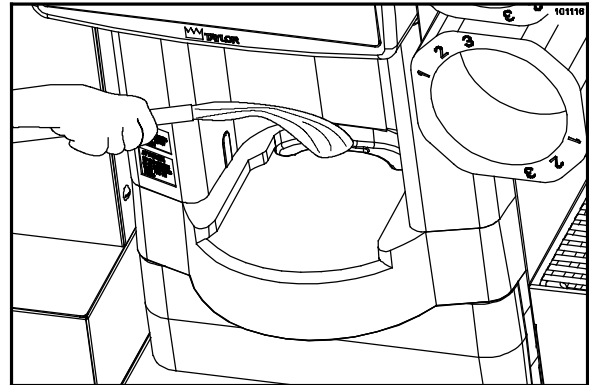

Figure 124

78. Carefully spray the proper amount of drain cleaning solution into the rinse station drain hole. (See Figure 125.)

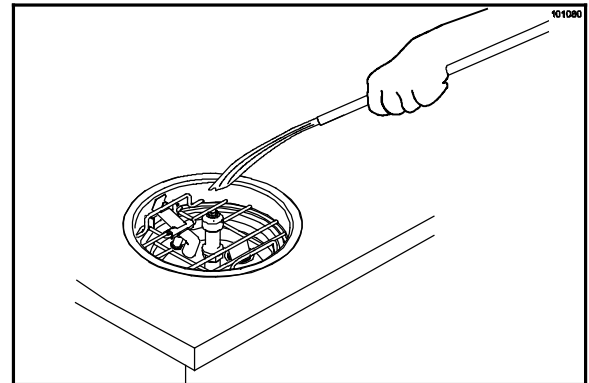

Figure 125

79. Press the NEXT key. The Cleaning screen will display. (See Figure 126.)

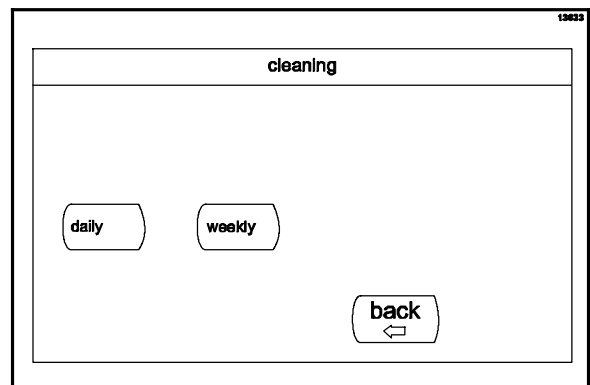

Figure 126



- Press the BACK key twice to return to the Beverage Selection screen.

**IMPORTANT! Do not use the drain for at least four hours after performing the weekly cleaning.**

**IMPORTANT! Do not calibrate for at least two hours after performing the weekly cleaning.**

## WEEKLY CALIBRATION PROCEDURES

### Ice Calibration

- Make sure the ice level is above the ADD ICE line on the hopper. Add ice, if needed. (See Figure 127.)

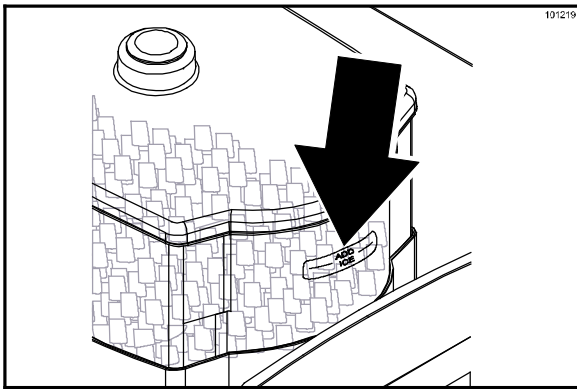

Figure 127

- Press the MENU key to display the Main Menu. (See Figure 128.)

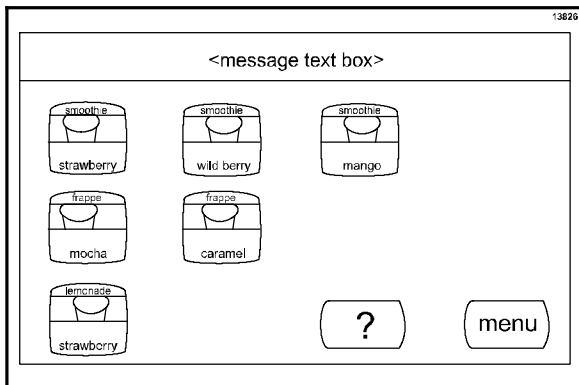

Figure 128

- Place a blender pitcher in the dispensing area. Press the ICE key until the pitcher is half full of shaved ice. Discard the ice into the back sink. (See Figure 129.)

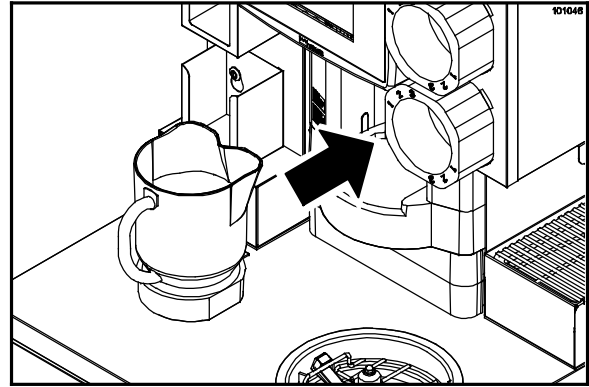

Figure 129

- Remove the splash guard. (See Figure 130.)

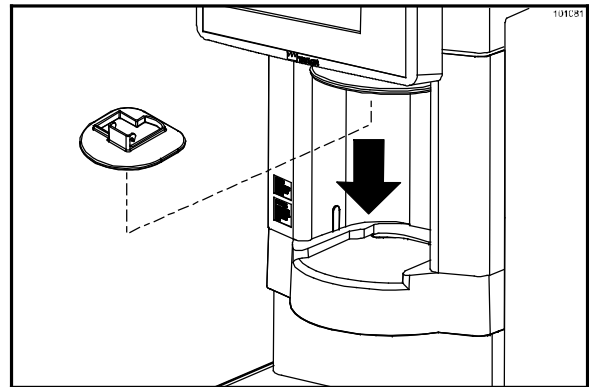

Figure 130

- From the Main Menu screen, press the CALIBRATE key. (See Figure 131.)

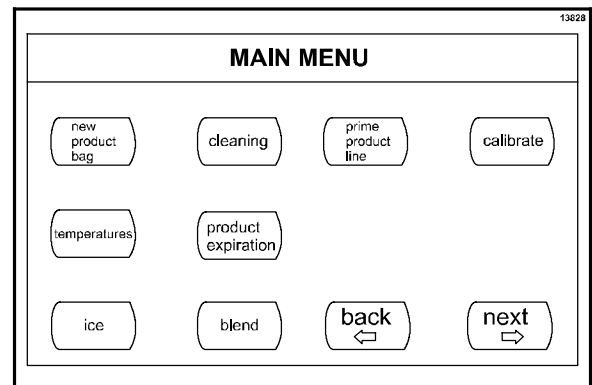

Figure 131

- The Calibrate screen will display. (See Figure 132.)

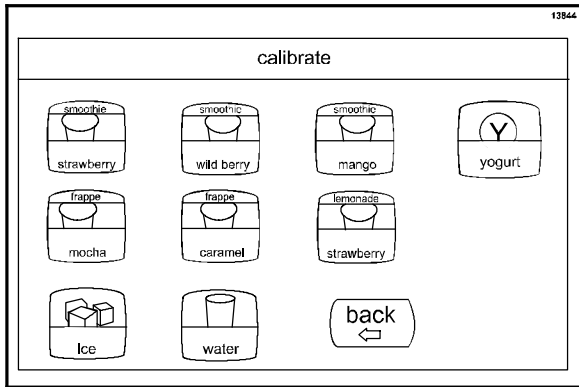

Figure 132

- Press the ICE key.
- Fill the large calibration cylinder with hot water from the coffee maker, up to the water level line. (See Figure 133.)



**CAUTION:** Use care when filling the calibration cylinder to avoid a scald injury.

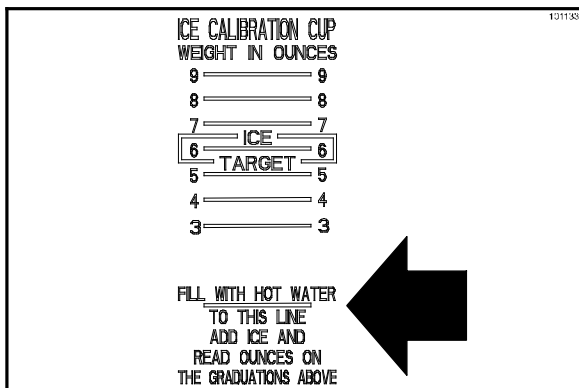

Figure 133

- Hold the large cylinder under the ice chute. Press the NEXT key to shave the ice. (See Figure 134.)

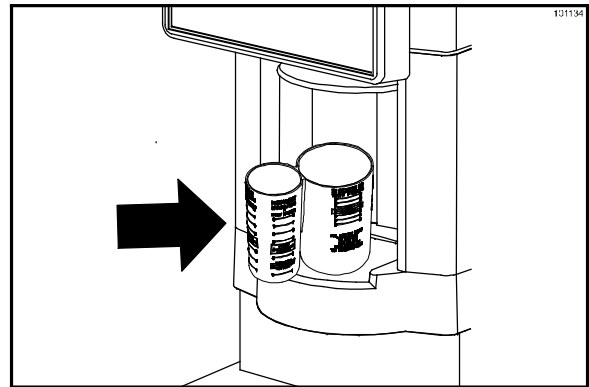

Figure 134

- Tap the cylinder a couple of times so the ice will settle. Do not push the ice down into the cylinder. (See Figure 135.)

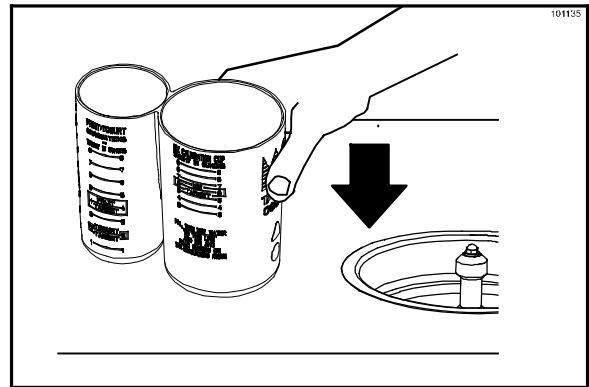

Figure 135

The level of water should be within the target window on the cylinder. (**Note:** 6 oz of ice should shave in 3 seconds.) (See Figure 136.)

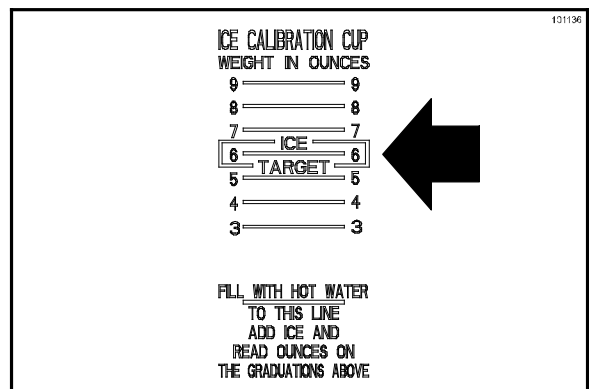

Figure 136

- If the level of water is within range, press the OK key.
- If the level of water is not within range, remember the weight number and press the NEXT key. Enter the amount of water dispensed, including the decimal point, and press the ENTER key. (See Figure 137.)

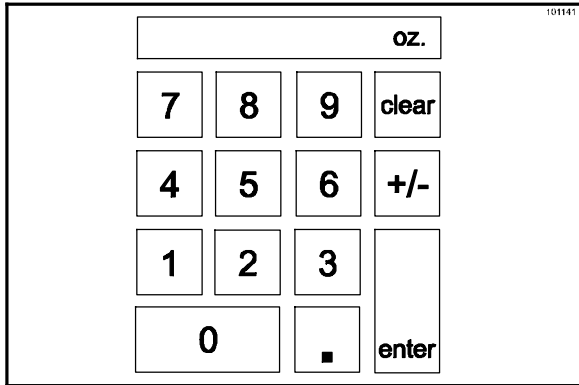

Figure 137

- Discard the water into the back sink. (See Figure 138.)

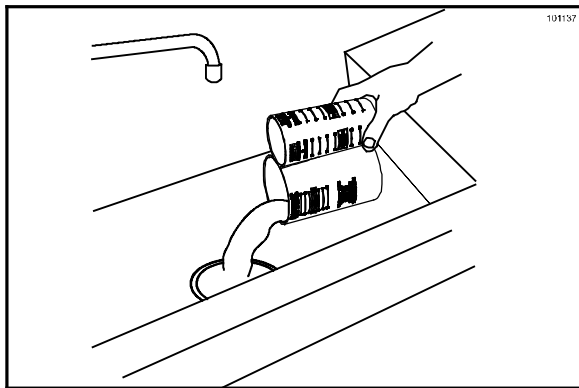

Figure 138

- Press the BACK key to return to the Calibrate screen or re-verify the calibration by pressing the NEXT key and repeating the calibration procedure.

**Note:** If unit is still unable to shave 6 oz of ice within 3 seconds, evaluate the ice quality. If the problem persists, replace the shaver blade, using the instructions starting on page 52.

- Reinstall the splash guard. (See Figure 139.)

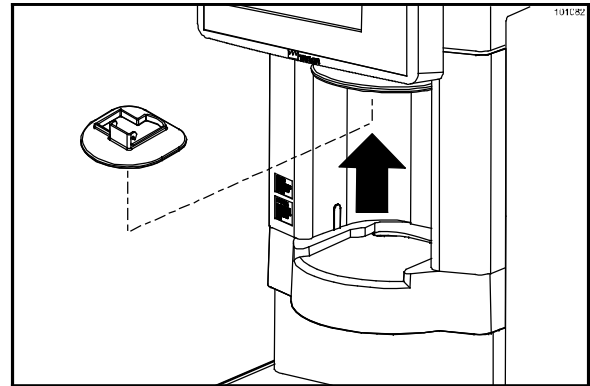

Figure 139

### Product Calibration

- Remove the splash guard. (See Figure 140.)

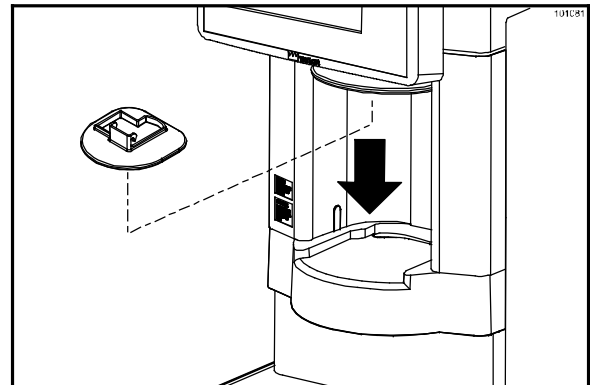

Figure 140

- Press the MENU key. (See Figure 141.)

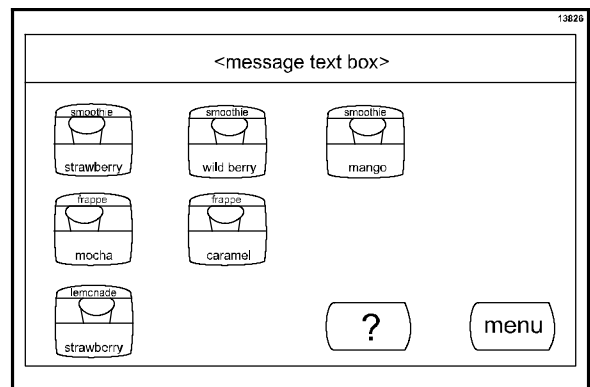

Figure 141

- From the Main Menu screen, press the CALIBRATE key. (See Figure 142.)

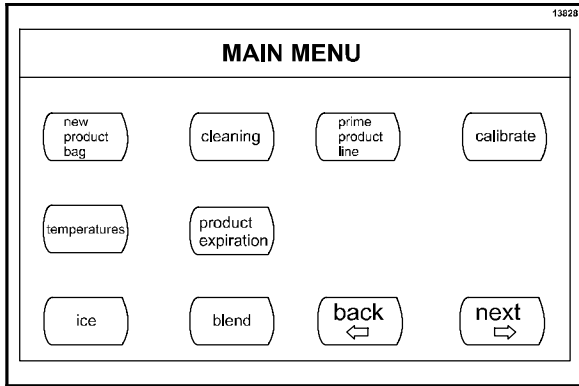

Figure 142

- The Calibrate screen will display. (See Figure 143.)

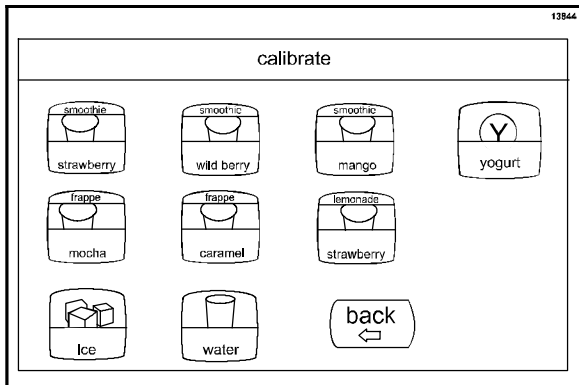

Figure 143

- Press the appropriate product key to be calibrated.
- Hold the small calibration cylinder under the dispensing head and press the NEXT key. (See Figure 144.)

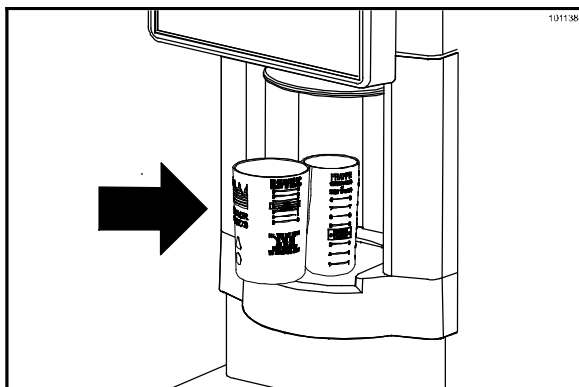

Figure 144

- Check the product level, using the appropriate scale for each type of product: Fruit/Lemonade, Frappe, and Yogurt. (See Figure 145.)

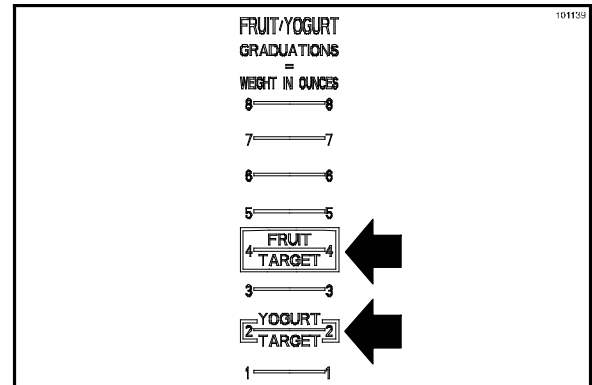

Figure 145

The level of product should be within the target window on the cylinder. (See Figure 146.)

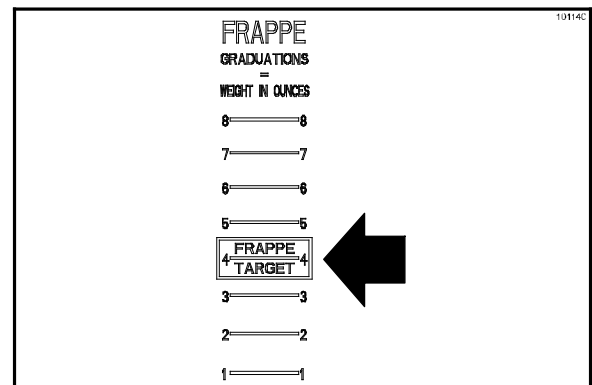

Figure 146

- If the level of product is within range, press the OK key.
- If the level of product is not within range, remember the weight number and press the NEXT key. Enter the amount of product dispensed, including the decimal point, and press the ENTER key. (See Figure 147.)

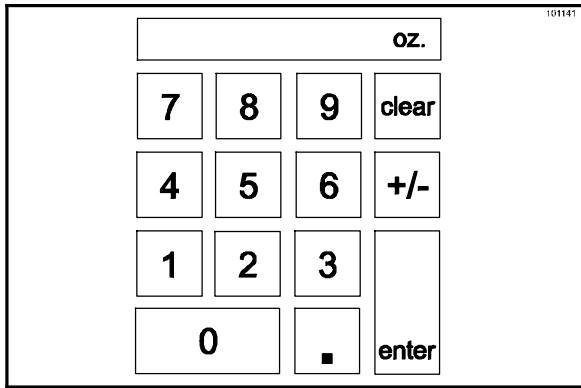

Figure 147

- Discard the product into the back sink. (See Figure 148.)

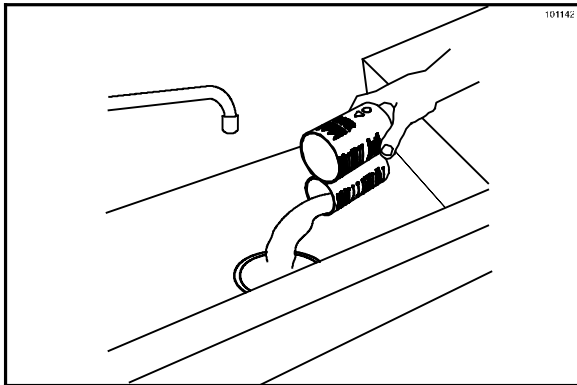

Figure 148

- Press the BACK key to return to the Calibrate screen or re-verify the calibration by pressing the NEXT key and repeating the calibration procedure.
- Reinstall the splash guard. (See Figure 149.)

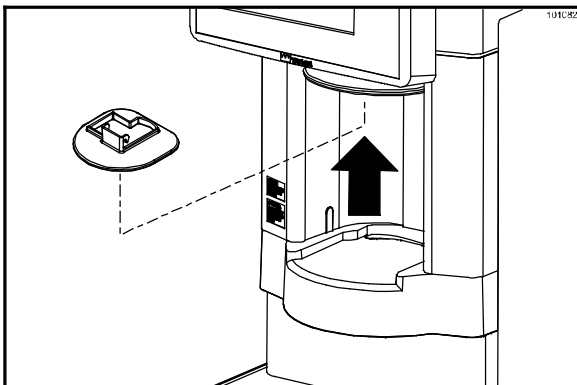

Figure 149

## Clearing Clogged Product Line

- Fill the cleaning bottle with a warm, approved sanitizing solution containing an active chlorine concentrate of 100 - 200 PPM. (See Figure 150.)

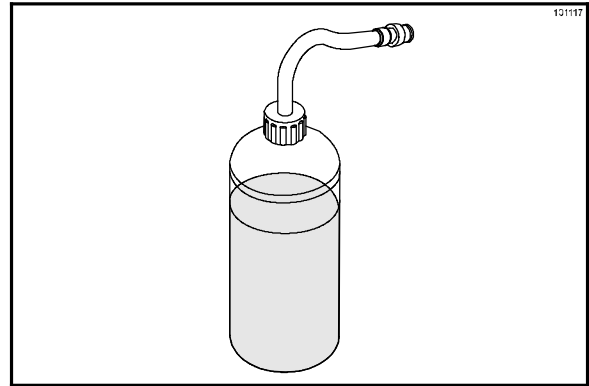

Figure 150

- Place a blender pitcher in the dispensing area. (See Figure 151.)

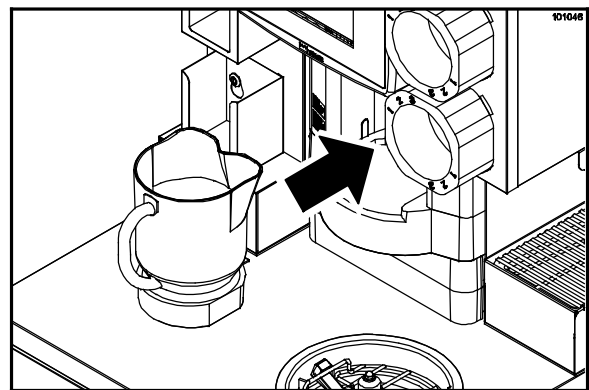

Figure 151

- Remove the appropriate product bin. (See Figure 152.)

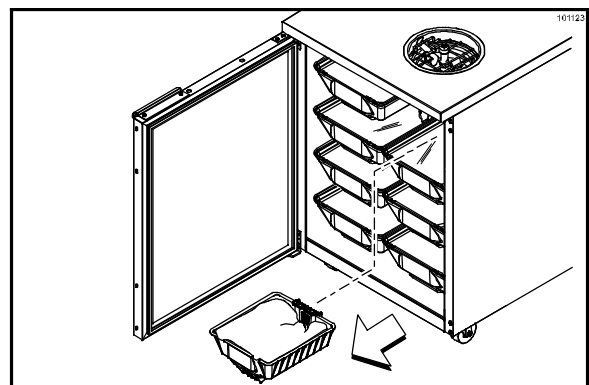

Figure 152

- Remove the product bin shelf.  
(See Figure 153.)

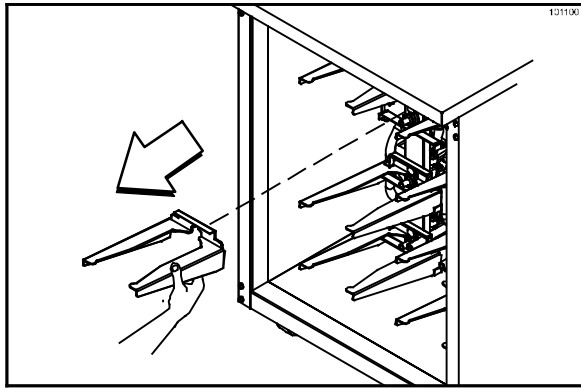

Figure 153

- Install one of the cleaning tubes on the fitting of the clogged product line.  
(See Figure 154.)

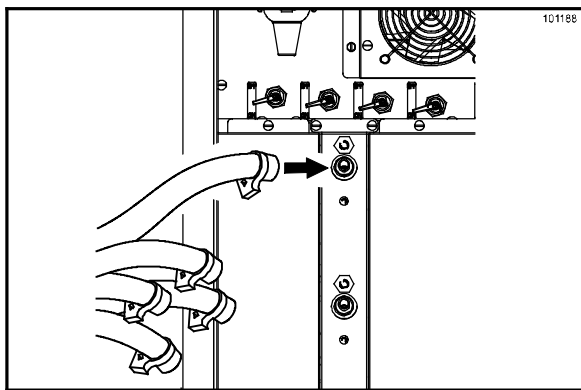

Figure 154

- Make sure the CO2 valve is in the “down/on” position so the pump is open.  
(See Figure 155.)

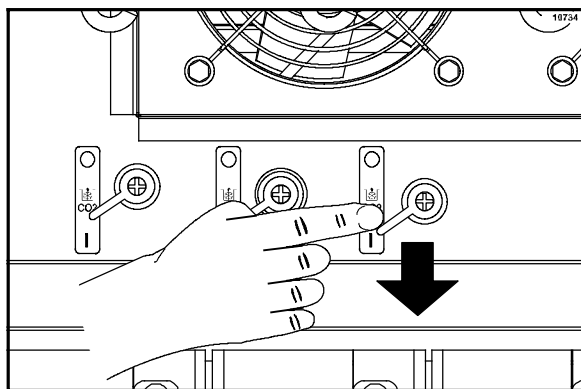

Figure 155

- Insert the bottle adaptor into the other end of the cleaning tube. (See Figure 156.)

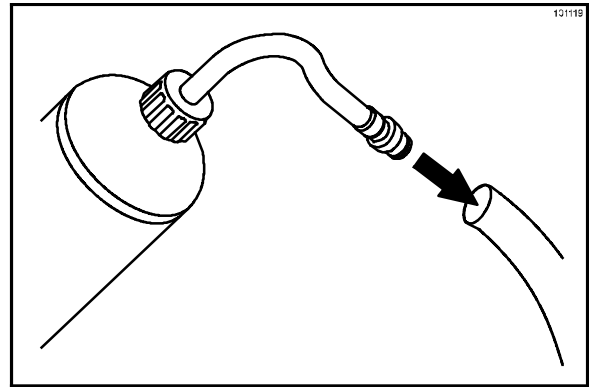

Figure 156

- Press the MENU key from the Beverage Selection screen to display the Main Menu screen. (See Figure 157.)

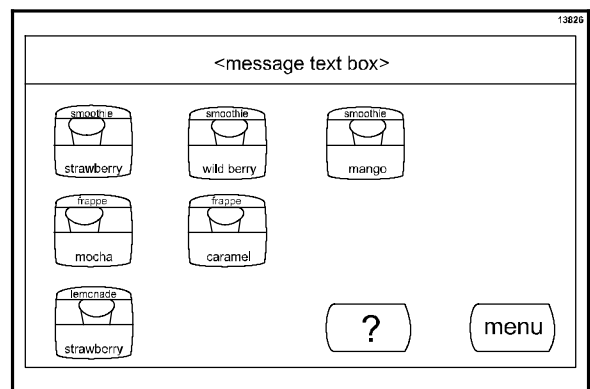

Figure 157

- Press the Prime Product Line key.  
(See Figure 158.)

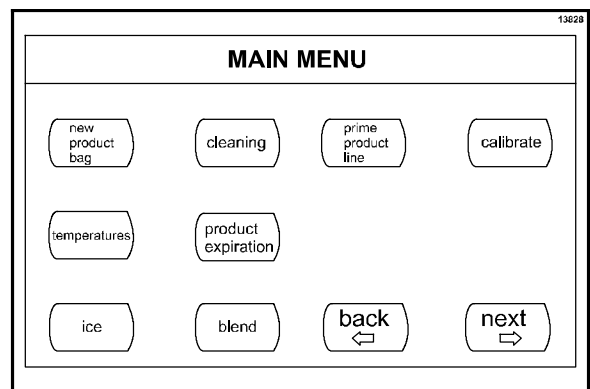

Figure 158

- Squeeze the cleaning bottle to fill the cleaning tube with sanitizing solution. (See Figure 159.)

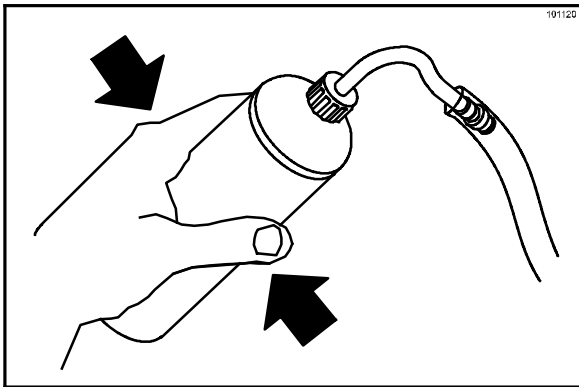

Figure 159

- Press the appropriate product key and squeeze the cleaning bottle while the product line is priming. (See Figure 160.)

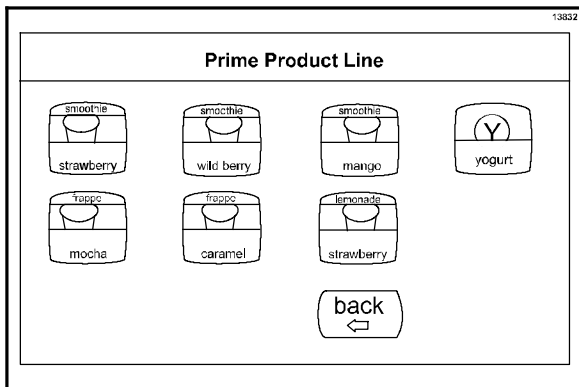

Figure 160

A bar graph screen will display the progress of the priming. (See Figure 161.)

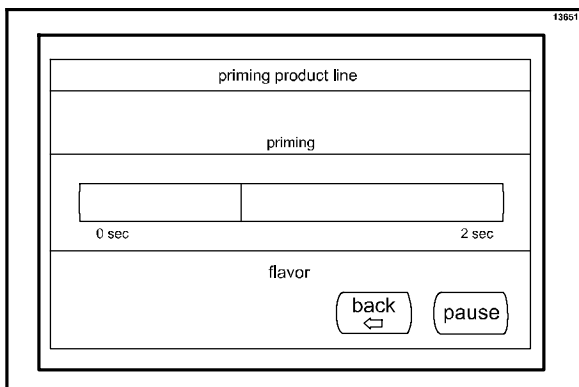

Figure 161

- Repeat the cleaning procedures until sanitizing solution enters the blender pitcher.

**(Note:** If sanitizing solution doesn't enter the blender pitcher after several attempts, turn off the CO2 valve and contact your Taylor Distributor.)

- Remove the cleaning tube from the product line fitting.

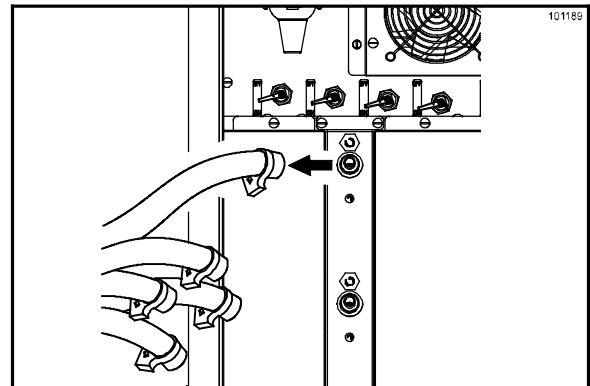

Figure 162

- Install the product bin shelf.
- Install the product bin.
- Press the MENU key from the Beverage Selection screen to display the Main Menu screen. (See Figure 163.)

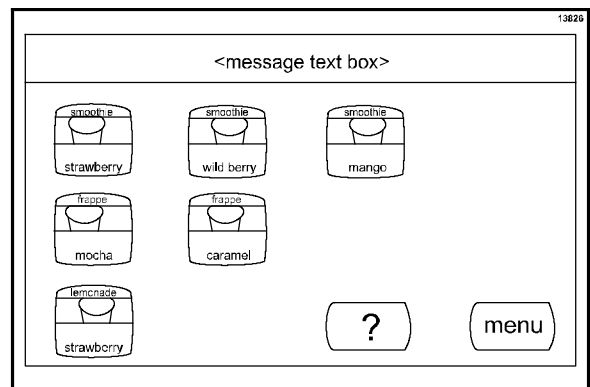

Figure 163

17. Press the Prime Product Line key.  
(See Figure 164.)

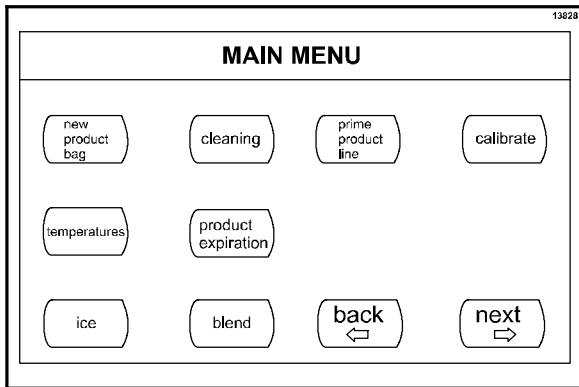

Figure 164

18. Press the appropriate product key.  
(See Figure 165.)

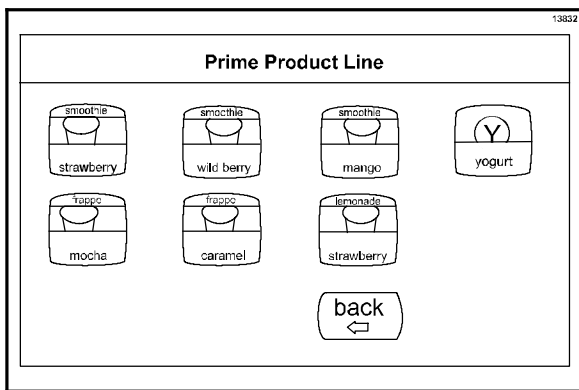

Figure 165

19. The product bag will begin priming. A bar graph screen will show the progress of the priming. (See Figure 166.)

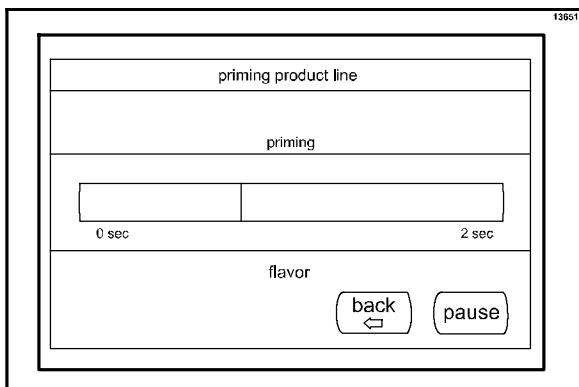

Figure 166

20. When the bag has finished priming, the screen will return to the Beverage Selection Screen. (See Figure 167.)

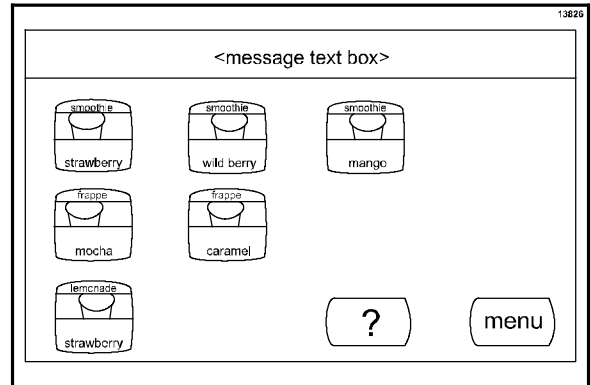

Figure 167

21. Discard the sanitizing solution in the blender pitcher into the back sink.

## LCD SCREENS

The color touch screen control is located above the blender/dispensing area.

**Note:** The product keys have color-coded borders to indicate the product condition.

Green = Selected Product

Yellow = Product Low

Red = Product Out

## MAIN MENU

Main Menu access is accomplished by pressing the MENU key on the Beverage Selection screen. When the Menu key is pressed, the following keys are displayed.

- New Product Bag
- Cleaning
- Prime Product Line
- Calibrate
- Ice
- Blend
- Temperatures
- Product Expiration

## New Product Bag

For detailed instructions to replace a product bag, refer to the Product Bag Replacement Procedure, starting on page 16.



## Cleaning

When the Cleaning key is pressed, the Daily and Weekly Cleaning keys become available.

For detailed instructions, refer to the Daily Opening Procedures starting on page 14 or the Weekly Cleaning Procedures starting on page 25.

## Prime Product Line

The Prime Product Line screen can be used to prime a partially filled product bag.

1. Place a blender pitcher in the dispensing area. (See Figure 168.)

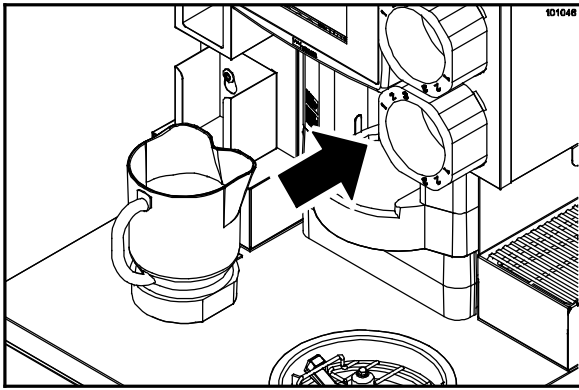

Figure 168

2. Press the Prime Product Line key to display the Prime Product Line screen.
3. Press the appropriate product key.
4. The product bag will begin priming. A bar graph screen will show the progress of the priming. (See Figure 169.)

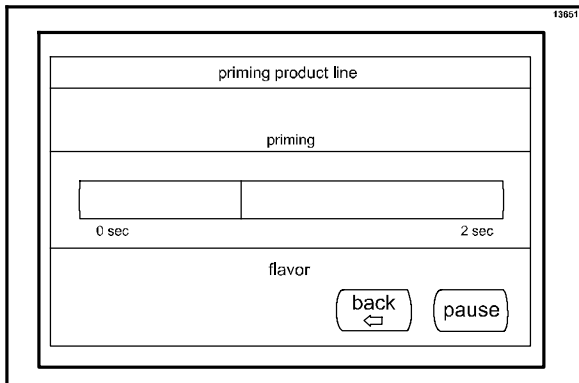

Figure 169

When the bag has finished priming, the screen will return to the Beverage Selection Screen. (See Figure 170.)

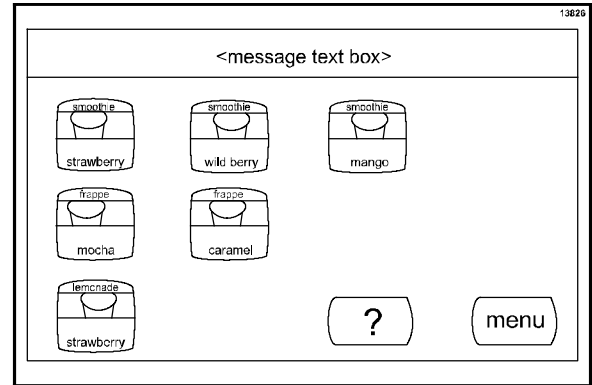

Figure 170

## Calibrate

For detailed instructions to calibrate ice and product, see the Weekly Calibration Procedures, starting on page 39.

## Ice

The ICE key is used to shave ice. With a blender pitcher placed in the dispensing area, press the ICE key until the desired amount of ice has been shaved.

## Blend

The Blend screen is used for additional blending of a drink. Press and hold the BLEND key to activate the blender.

## Temperatures

The Temperatures screen is used to display the current cabinet and dispenser head temperatures.

## Product Expiration

The Product Expiration screen displays the expiration date for each product. The product expiration for the flavors is 14 days. The production expiration for yogurt is 7 days. (See Figure 171.)

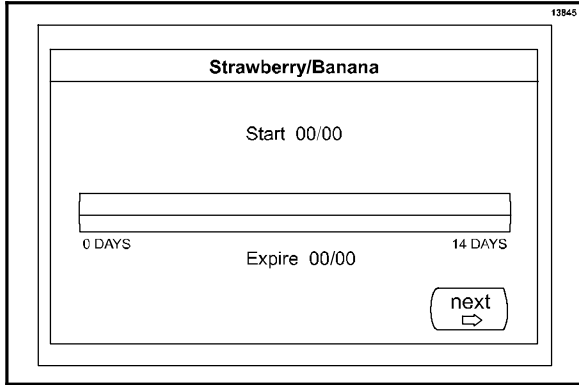

Figure 171

## MANAGER MENU

There are three levels of menu access: Main, Manager, and Service. Each level of access allows access to a greater number of menu options.

To access the Manager Menu, press the MENU key on the Beverage Selection screen. On the Main Menu screen, press the NEXT key. The following screen will display. (See Figure 172.)

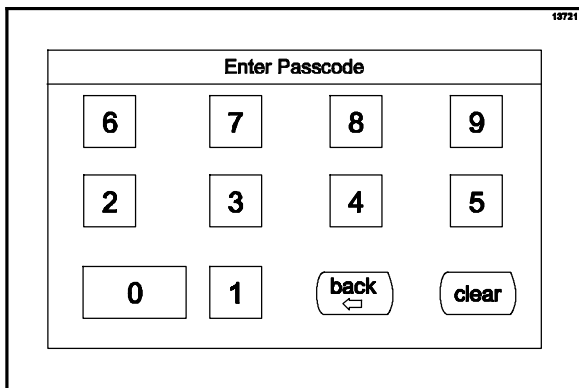

Figure 172

Enter Manager Menu access code **3 3 1 2**.

The following keys are displayed on the Manager Menu screen. Press the appropriate key on the Manager Menu to enter the screen.

- Set Clock
- Reset to Defaults
- Menu
- Scale
- Rinse
- Manual Defrost
- Drain Pause
- Version
- Software Update

## Set Clock

The Set Clock screen is used to set the clock calendar, (time and date). The time and date are displayed in the top line of the numeric keypad screen in the following format:

16:18 08/22/09

The time is in 24 hour format where the time is 00:00 (12:00 am, midnight) to 23:59 (11:59 pm).

To enter the above time and date, the operator would press the following keys: 1, 6, 1, 8, 0, 8, 2, 2, 0, 9. If an incorrect key is pressed, the operator must press the BACK key to exit this screen and then press the Set Clock key to re-enter the Set Clock numeric keypad screen. The time and date are not saved until the OK key is pressed. The OK key can be pressed at any time during the time and date editing, for what is displayed is what is saved. Therefore, if only the hour required changing, the entire time/date string does not have to be edited. (See Figure 173.)

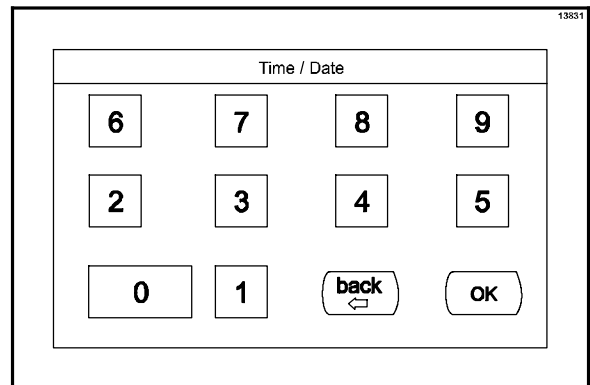

Figure 173

When the OK key is pressed, the time/date displayed is saved.

The Daylight Savings time screen will display. Press the ON key to enable daylight savings time or the OFF key to disable daylight savings time. (See Figure 174.)

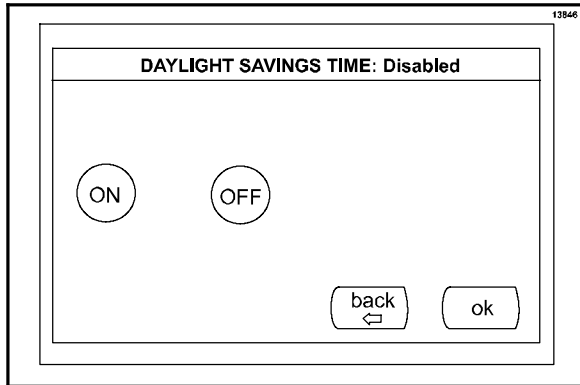

Figure 174

Press the OK key to confirm the selection. The screen will return to the Main Menu.

**(Note:** Pressing the BACK key instead of the OK key returns to the Main Menu without saving any changes.)

### Reset to Defaults

This menu is used to reset to factory defaults. The first Reset to Defaults screen displays a BACK and a NEXT key. Pressing the BACK key will return to the Manager Menu. Pressing the NEXT key will advance to the second Reset to Defaults screen which states, "Are You Sure?" Pressing the NEXT key will display a screen stating, "Initializing" and then "UVC Control". Press the NEXT key.

The screen will display "Check Settings" and "CALIBRATION REQ'D". Press the NEXT key. The screen will return to the Beverage Selection screen.

### Menu (Beverage Select)

This screen allows the user to select the beverages to display in the Beverage Selection screen. The first screen to appear displays all of the selectable beverages. The beverage icons will all have a green border around them to indicate that they will display on the Beverage Selection screen. (See Figure 175.)

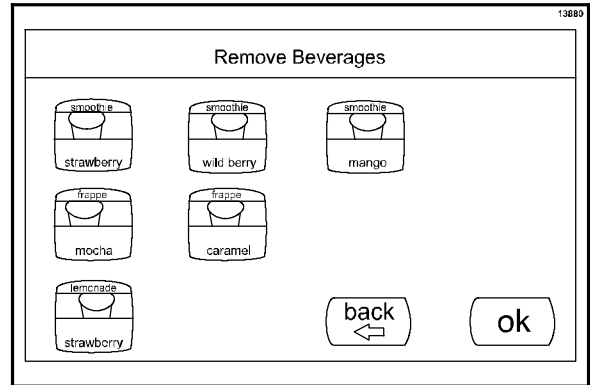

Figure 175

To remove a beverage, press the applicable icon. This will remove the green border. Press the OK key to confirm the selection and proceed to the "Remove Options" screen. (See Figure 176.)

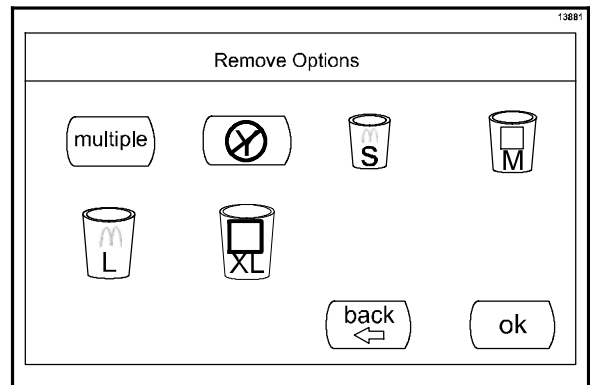

Figure 176

**Note:** To return to the Manager Menu without making a beverage change, press the BACK key.

The “Remove Options” screen allows the user to select the options to display in the Beverage Selection screen. All of the selectable options are displayed. To remove an option, press the applicable icon. The deselected icons will change to a light grey color.

Pressing the OK key will save and display only the options that were not removed. (**Note:** To return to the Manager Menu without making an option change, press the BACK key.)

### Select Temperature Scale

The Select Temperature Scale menu allows the operator to select which temperature scale to use when displaying temperature; Fahrenheit or Celsius. The current temperature scale is displayed in the text bar at the top of the screen.

If Fahrenheit is desired, press the ON key. If Celsius is desired, press the OFF key. Pressing the BACK key will return to the Manager Menu without any change to the setting. Pressing the OK key will save the selected scale.

### Set Rinse Time

The Set Rinse Time menu allows the operator to set the time that the rinser runs when a pitcher is placed on the rinser. The first screen displays the range of values that are valid. Pressing the NEXT key will display the numeric keypad screen to allow entry of the Rinse Time. Enter the desired time by pressing the numbers on the display screen. Press the OK key to confirm the selection.

### Defrost

In the Defrost Menu, the operator can perform a defrost cycle immediately by pressing the Manual Defrost key or he can schedule defrost cycles by pressing the Schedule key. (See Figure 177.)

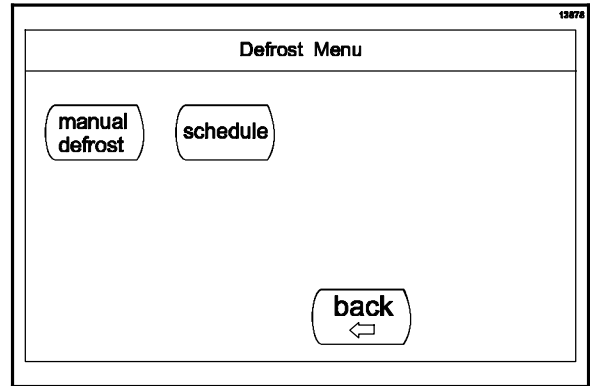

Figure 177

The Manual Defrost Menu allows the operator to manually start a defrost cycle. Press the ON key to enable manual defrost or the OFF key to disable manual defrost. Press the OK key to confirm the selection. (See Figure 178.)

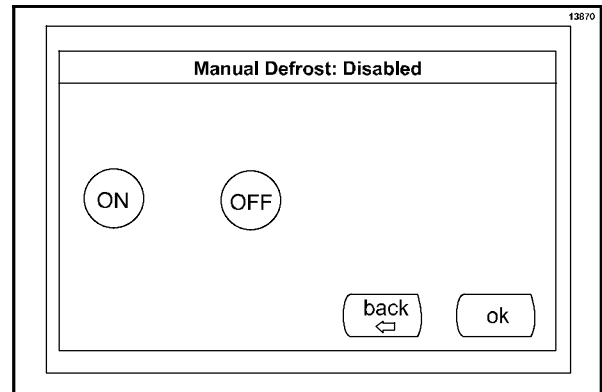

Figure 178

**Note:** Pressing the BACK key instead of the OK key returns to the Manager Menu without starting a manual defrost cycle.

The Schedule Defrost Menu allows the operator to either select the Intelligent Mode or the number of defrost cycles to run daily.

If the Intelligent Mode is selected, a defrost cycle will only be performed if the system determines that a defrost cycle is necessary.

As an alternative to the Intelligent Mode, the operator can set the system to perform from one to four automatic defrosts daily by pressing the key for the number of daily defrost cycles desired.

The current mode is displayed at the top of the screen. In the example below, the current mode is the Intelligent Mode.

(See Figure 179.)

**Note:** Pressing the BACK key will return to the Defrost Menu without making any selection.

After the Intelligent Mode key or one of the numeric keys is pressed, a screen is displayed to allow confirmation of the new setting. The new setting is displayed at the top of the screen. Pressing the BACK key will return to the Set Daily Defrost Cycles menu without making any changes to the setting. Pressing the OK key will save the new setting and return to the Manager Menu.

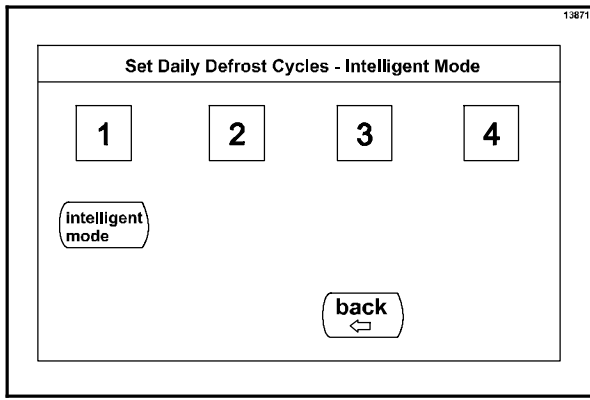

Figure 179

The following table shows the schedule for defrost cycles. The defrost cycle takes three minutes to perform.

| Defrost Mode | First Cycle  | Second Cycle | Third Cycle | Fourth Cycle |
|--------------|--------------|--------------|-------------|--------------|
| Intelligent  | As Necessary |              |             |              |
| 1 per day    | 0300         |              |             |              |
| 2 per day    | 0300         | 1500         |             |              |
| 3 per day    | 0300         | 1100         | 1900        |              |
| 4 per day    | 0300         | 0900         | 1500        | 2100         |

### Set Drain Pause

The Set Drain Pause menu allows the operator to set the time between sequential pumping actions. This is done to allow time for the rinser sink to empty before the next pump is activated, to help prevent the rinser sink from overflowing during weekly cleaning.

The first screen displays the range of values that are valid. Pressing the NEXT key will display the numeric keypad screen to allow entry of the Rinse Time.

Enter the desired time by pressing the numbers on the display screen. Press the OK key to confirm the selection.

### Version

Pressing the Version key on the Manager Menu screen will display the UVC software version.

Press the NEXT key. The Shaver/Blender version will display.

Press the NEXT key. The User Interface version will display.

Press the NEXT key. The screen will return to the Manager Menu screen.

Press the BACK key twice to return to the Beverage Selection screen.

### Software Update

The Software Update menu allows the operator to install software updates, using the SD card.

### SHAVER BLADE REPLACEMENT

1. Remove the ice hopper cover. Scoop out as much ice as possible, using a clean, sanitized ice scoop. (See Figure 180.)



**Use caution when removing ice near the shaver blade area.** Failure to follow this instruction could result in personal injury from blade contact.

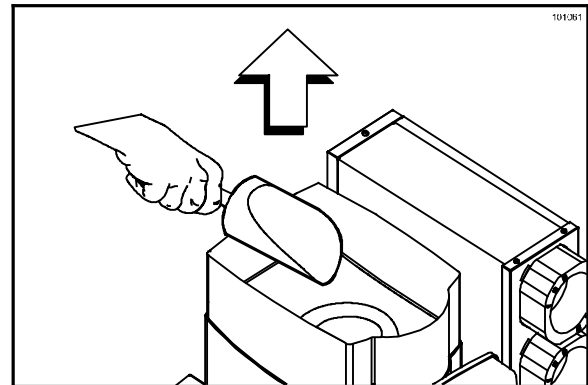

Figure 180

2. Reinstall the ice hopper cover. (See Figure 181.)

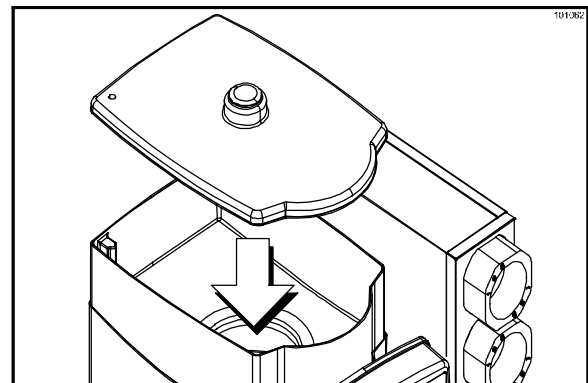

Figure 181

3. Press the ICE key until all remaining ice has dispensed into the blender pitcher.
4. Remove the blender pitcher and discard the ice into the back sink. (See Figure 182.)

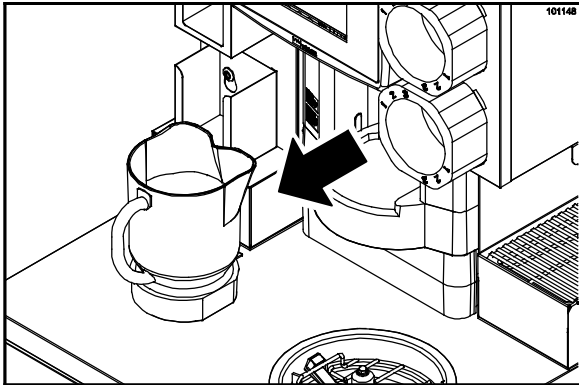



Figure 182

5.  **Place the power switch in the OFF position.** Failure to follow this instruction may result in severe personal injury from hazardous moving parts.
6. Remove the ice hopper and cover. Take them to the 3-compartment sink. (See Figure 183.)

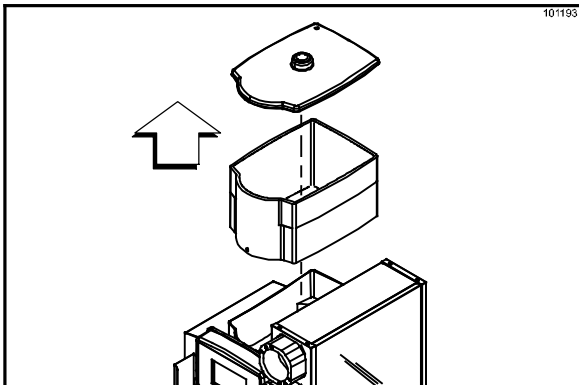

Figure 183

7. Remove the splash guard and ice shaver chute. Take them to the 3-compartment sink. (See Figure 184.)

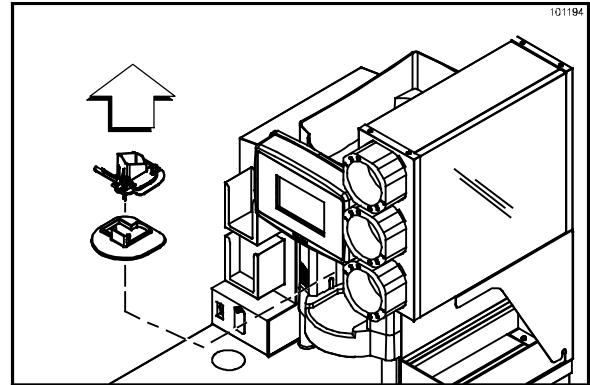

Figure 184

8. Wash, rinse, and sanitize these parts in the 3-compartment sink.

**Note:** When sanitizer is used, it must always have a contact time of 5 minutes. Afterward, if required by your Local code, rinse with clean water.

9. Remove the plastic ice shaver assembly cover by pressing the center tab and turning the cover clockwise. This unlocks the ice shaver blade. (See Figure 185.)

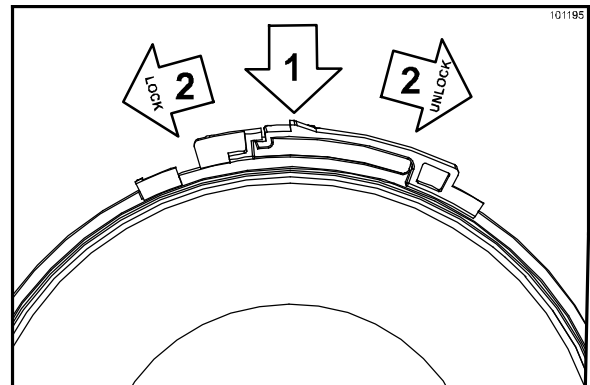

Figure 185



**Use caution when performing the following steps.** Failure to follow this instruction could result in personal injury from blade contact.

10. Install a blade guard on the old ice shaver blade. (See Figure 186.)

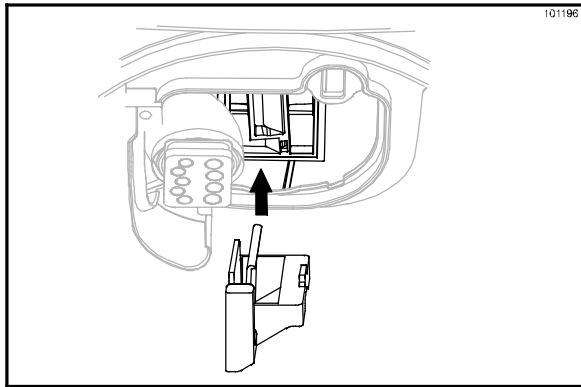

Figure 186

11. Remove the old ice shaver blade by pushing the blade forward toward the opening in the ice shaver assembly. The blade will drop down for removal. (See Figure 187.)

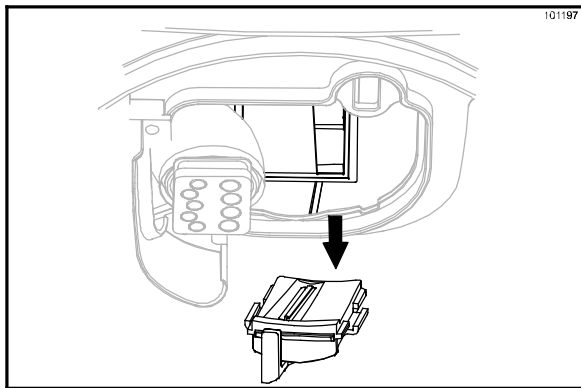

Figure 187

12. Install a new blade with guard by inserting the blade into the opening and pushing it back into place. (See Figure 188.)

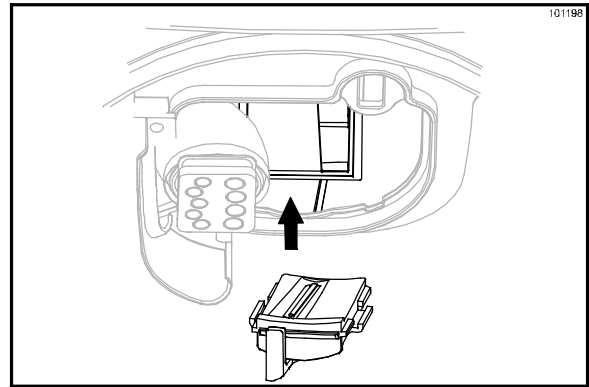

Figure 188

13. Remove the blade guard from the new blade. (See Figure 189.)

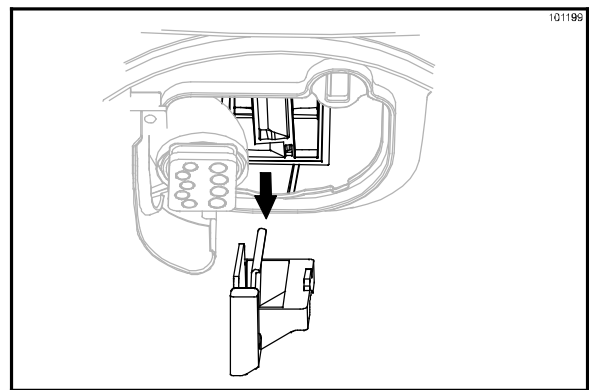

Figure 189

**IMPORTANT:** The blade guard must be removed before installing the ice shaver assembly cover.



14. Reinstall the ice shaver assembly cover by using the arrows to line up the cover with the ice shaver assembly. Turn the cover counter-clockwise, locking the cover in place. (See Figure 190.)

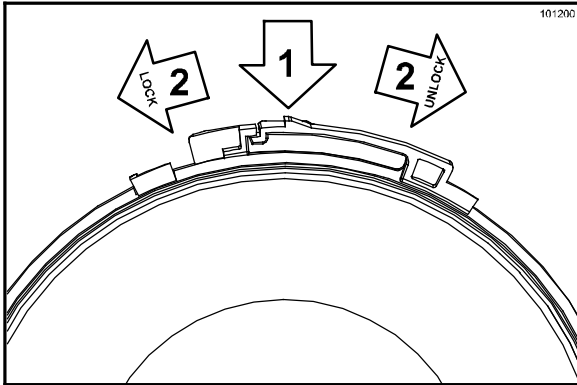

Figure 190

15. Sanitize the ice shaver assembly by following the instructions starting on page 29.

16. Reinstall the sanitized ice chute, splash guard, blender pitcher, ice hopper and ice hopper cover. (See Figure 191.)

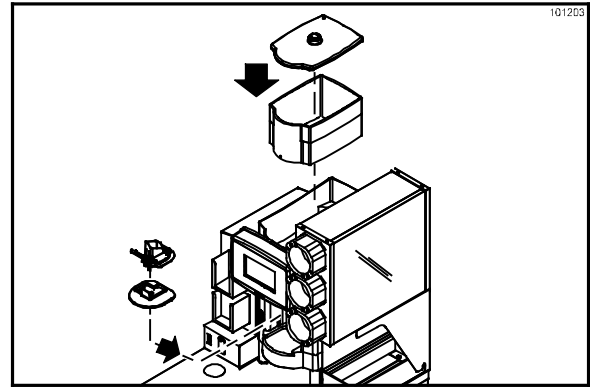

Figure 191

17. Place the power switch in the ON position.
18. Press the ICE key and check the shaver operation.

## TROUBLESHOOTING GUIDE

| PROBLEM                                    | PROBABLE CAUSE  | REMEDY  |
|--|---|---|
| The display screen is blank or frozen.     | The power switch is off.                                  | Place the power switch in the ON position. Wait two minutes for the screen to display.  |
|  | The interface control is wet.                             | Turn the power switch off for one minute. Place the power switch in the ON position and wait two minutes for the screen to display. |
| Machine will not dispense <b>product</b> . | The product bag is empty.                                 | Install a new product bag, following the proper installation procedures.  |
|  | The product bag is not properly installed in the mix bin. | Re-install the product bag, following the proper installation procedures.   |
|  | There isn't a blender pitcher in the dispensing area.     | Place a blender pitcher into the dispensing area.   |
|  | The product line is clogged.                              | Perform the product line cleaning procedures.   |
|  | The unit is locked out for the 7 day cleaning.            | Perform the 7 day cleaning.   |
|  | The CO2 valve inside the cabinet is turned off.           | Place the CO2 valve in the ON position.   |
|  | The CO2 line at the back of the unit is unplugged.        | Plug in the CO2 line.   |
|  | The CO2 line at the back of the unit is kinked.           | Straighten the CO2 line.  |
|  | The CO2 bulk tank is low or empty.                        | Call the CO2 supplier to refill.  |

| PROBLEM   | PROBABLE CAUSE  | REMEDY  |
|---|---|---|
| Machine will not dispense <b>ice</b> .                      | The ice hopper is empty.                                  | Refill the ice hopper.  |
|   | Ice is melted together (bridging) in the ice hopper.      | Use a sanitized cup to push the ice into the middle of the ice hopper and then refill the ice hopper. <b>Note:</b> The ice must be removed every night during Closing Procedures. |
|   | The ice chute is blocked.                                 | Place the power switch in the OFF position. Clear the ice restriction. <b>Note: To prevent injury, DO NOT use your fingers to clear the restriction.</b>                          |
|   | The ice hopper cover is not installed properly.           | Make sure the ice hopper cover is properly seated.  |
|   | There isn't a blender pitcher in the dispensing area.     | Place a blender pitcher into the dispensing area.   |
|   | The unit is locked out for the 7 day cleaning.            | Perform the 7 day cleaning.   |
| Unit is under-filling or over-filling the blender pitchers. | The product, ice, or yogurt is out of calibration.        | Recalibrate. (Note: If 6 oz of ice doesn't shave within 3 seconds, evaluate ice quality/call service technician to evaluate blade.)   |
|   | The ice hopper is out of ice.                             | Refill the ice hopper.  |
|   | Ice is melted together (bridging) in the ice hopper.      | Use a sanitized cup to push the ice into the middle of the ice hopper and then refill the ice hopper. <b>Note:</b> The ice must be removed every night during Closing Procedures. |
|   | The ice chute is blocked.                                 | Place the power switch in the OFF position. Clear the ice restriction. <b>Note: To prevent injury, DO NOT use your fingers to clear the restriction.</b>                          |
|   | The product bag is not properly installed in the mix bin. | Re-install the product bag, following the proper installation procedures.   |
|   | The incorrect portion size was dispensed.                 | Select the correct portion size.  |
|   | The pinch valve is faulty or worn.                        | Call service technician.  |
|   | The CO2 pressure is too low.                              | Call service technician.  |
|   | The CO2 bulk tank is low.                                 | Call the CO2 supplier to refill.  |

| <b>PROBLEM</b>   | <b>PROBABLE CAUSE</b>   | <b>REMEDY</b>   |
|--|---|---|
| The pitcher rinser is not working.   | The water line at the back of the unit is disconnected.               | Connect in the water line.  |
|  | The water line at the back of the unit is kinked.                     | Straighten the water line.  |
|  | Low water pressure in store.  | Call service technician.  |
|  | The rinser actuator was improperly installed.                         | Correctly install the rinser actuator.  |
|  | The rinser actuator is faulty.  | Replace the rinser actuator.  |
|  | The rinser actuator is not moving freely.                             | Remove, clean, and reinstall the rinser actuator.   |
| The rinser drain is slow.  | The drain is clogged.   | Pour hot water into the drain until the problem is resolved. Ensure weekly drain cleaning is being performed, per PM card BE22W1. |
| Product is leaking inside the cabinet.   | The product bag is not properly installed.                            | Re-install the product bag, following the proper installation procedures.   |
|  | There is a tear in the product bag or in the spout.                   | Install a new product bag, following the proper installation procedures.  |
| The unit is leaking CO2.   | The CO2 valve of an unused pump was not shut off.                     | Shut the CO2 valve off.   |
| Product Low LED is blinking, but product bag is not low.   | Product control did not reset when the new product bag was installed. | Follow the proper product bag replacement procedures.   |
| The temperatures of the dispenser head and/or the product cabinet are reading over 40° F (5° C) for over 30 minutes. | Fault is displayed.   | Check product temperature. If temperature is over 40° F (5° C), discard product. Call service technician.                         |
| Product keeps dripping from the dispenser head.  | Worn pinch/product tube.  | Call service technician.  |
|  | Faulty pinch valve.   | Call service technician.  |

## PARTS REPLACEMENT SCHEDULE

| DESCRIPTION       | EVERY<br>3 MONTHS | EVERY<br>6 MONTHS                 | ANNUALLY |
|-------------------|-------------------|-----------------------------------|----------|
| Brushes           |                   | Inspect & Replace<br>if Necessary | Minimum  |
| Shaver Blade      |                   |                                   | X        |
| *Pinch Tubes      |                   |                                   | X        |
| *Water Filter     |                   |                                   | X        |
| *CO2 Filter       |                   |                                   | X        |
| *Motor Shaft Seal |                   |                                   | X        |

\*Must be replaced by an authorized service technician.

## PARTS WARRANTY EXPLANATION

### **Class 103 Parts**

The warranty for new equipment Class 103 parts is one year from the original date of unit installation, with a replacement parts warranty of three months.

### **Class 212 Parts**

The warranty for new equipment Class 212 parts is two years from the original date of unit installation, with a replacement parts warranty of twelve months.

### **Class 512 Parts**

The warranty for new equipment Class 512 parts is five years from the original date of unit installation, with a replacement parts warranty of twelve months.

### **Class 000 Parts**

Class 000 parts are considered wear items - no warranty.

### **Class \*\*\* Parts**

See warranty explanation on the back of the check-out card.

**CAUTION:** Warranty is valid only if the parts are authorized Taylor parts, purchased from an authorized Taylor Distributor, and the required service work is provided by an authorized Taylor service technician.

Taylor reserves the right to deny warranty claims on equipment or parts if non-approved parts or refrigerant were installed in the machine, system modifications were performed beyond factory recommendations, or it is determined that the failure was caused by neglect or abuse.

## ORDERING/SERVICE INFORMATION

Taylor Distributor: \_\_\_\_\_

Address: \_\_\_\_\_

Phone: \_\_\_\_\_

Date of Installation: \_\_\_\_\_

### Data Plate

The data plate provides necessary information that the operator should record and refer to when calling for parts or service. The data plate is located on the rear or left side panel of the freezer.

Complete for quick reference when this information is requested.

1. Model Number: C029
2. Serial Number \_\_\_\_\_
3. Electrical Specs:  
Voltage \_\_\_\_\_ Cycle \_\_\_\_\_ Phase \_\_\_\_\_
4. Maximum Fuse Size: \_\_\_\_\_ Amps
5. Minimum Wire Ampacity: \_\_\_\_\_ Amps
6. Part Number: \_\_\_\_\_

### Parts Warranty

Warranty is valid only if the parts are authorized Taylor parts, purchased from an authorized Taylor Distributor, and the required service work is provided by a factory authorized service technician. Taylor reserves the right to deny warranty claims on equipment or parts if non-approved parts or refrigerant were installed in the machine, system modifications were performed beyond factory recommendations, or it is determined that the failure was caused by neglect or abuse.

**Note:** Constant research results in steady improvements; therefore, information in this manual is subject to change without notice.

### Compressor Warranty Disclaimer

The refrigeration compressor(s) on this machine are warranted for the term indicated on the warranty card accompanying this machine. However, due to the Montreal Protocol and the U.S. Clean Air Act Amendments of 1990, many new refrigerants are being tested and developed, thus seeking their way into the service industry. Some of these new refrigerants are being advertised as drop-in replacements for numerous applications. It should be noted that, in the event of ordinary service to this machine's refrigeration system, only the refrigerant specified on the affixed data plate should be used. The unauthorized use of alternate refrigerants will void your compressor warranty. It will be the owner's responsibility to make this fact known to any technician he employs.

It should also be noted that Taylor does not warrant the refrigerant used in its equipment. For example, if the refrigerant is lost during the course of ordinary service to this machine, Taylor has no obligation to either supply or

provide its replacement either at billable or unbillable terms. Taylor does have the obligation to recommend a suitable replacement if the original refrigerant is banned, obsoleted, or no longer available during the five year warranty of the compressor.

Taylor will continue to monitor the industry and test new alternates as they are being developed. Should a new alternate prove, through our testing, that it would be accepted as a drop-in replacement, then the above disclaimer would become null and void. To find out the current status of an alternate refrigerant as it relates to your compressor warranty, call the local Taylor Distributor or the Taylor Factory. Be prepared to provide the Model/Serial Number of the unit in question.











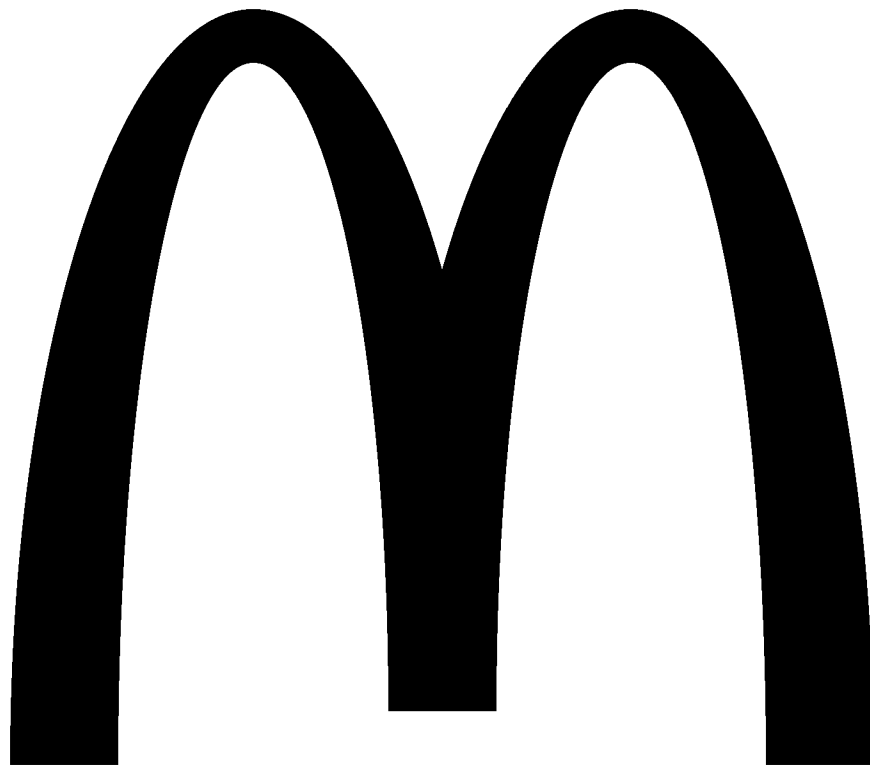

067214-M